

VT no. equal P 68

ARMY AIR FORCES
TECHNICAL ORDER NO. 08-10-119

INSTRUCTION BOOK
FOR
OPERATION and MAINTENANCE
OF
RADIO RECEIVER BC-348-E
RADIO RECEIVER BC-348-M
RADIO RECEIVER BC-348-P

RESTRICTED

NOTICE:—This document contains information affecting the national defense of the United States within the meaning of the Espionage Act, 50 U. S. C., 31 and 32, as amended. Its transmission or the revelation of its contents in any manner to an unauthorized person is prohibited by law. (AR 380-5)

The information contained in restricted documents and the essential characteristics of restricted material will not be communicated to the public or to the press, but may be given to any person known to be in the service of the United States and to persons of undoubted loyalty and discretion who are cooperating in Government work.

PUBLISHED BY AUTHORITY
OF
THE CHIEF SIGNAL OFFICER

December 15, 1942



REPORT OF MAJOR FAILURE

In the event of major failure of any of the component units of this equipment, a report shall be submitted in the form indicated below. Copies of this report shall be forwarded to the Chief of Signal Section, Air Service Command, Patterson Field, Ohio, and to the Director Signal Corps Aircraft Signal Service, Wright Field, Ohio.

- 1. Contract or Order Number.**
- 2. Organization and station.**
- 3. Nomenclature of Equipment.**
- 4. Nomenclature of component unit.**
- 5. Date and nature of failure.**
- 6. Type of airplane in which installed.**
- 7. Recommendations.**

Destruction of Abandoned Materiel in the Combat Zone

In case it should become necessary to prevent the capture of this equipment and when ordered to do so,

DESTROY IT SO THAT NO PART OF IT CAN BE SALVAGED, RECOGNIZED OR USED BY THE ENEMY. BURN ALL PAPERS AND BOOKS.

Means:-

1. Explosives, when provided.
2. Hammers, axes, sledges or whatever heavy object is readily available.
3. Burning by means of incendiaries such as gasoline, oil, paper or wood.
4. Grenades and shots from available arms.
5. Where possible, and when time permits, bury all debris or dispose of it in streams or other bodies of water.

Procedure:-

1. Obliterate all identifying marks. Destroy nameplates and circuit labels.
2. Demolish all panels, castings, switch- and instrument-boards.
3. Destroy all controls, switches, relays, connections and meters.
4. Rip out all wiring in electrical equipment. Smash gas, oil and water cooling systems in gas-engine generators, etc.
5. Smash every electrical or mechanical part whether rotating, moving or fixed.
6. Break up all operating instruments such as keys, phones, microphones, etc.
7. Destroy all classes of carrying cases, straps, containers, etc.

TABLE OF CONTENTS

SECTION I—GENERAL DESCRIPTION

<i>Paragraph</i>	<i>Page</i>
1. GENERAL	1
2. COMPONENT UNITS	1
3. CABINET	3
4. MOUNTING FT-154-E, FT-154-P or FT-154-W	3
5. PLUG PL-Q103 and PL-P103	3
6. CHASSIS	5
7. PANEL	5
8. DIAL AND MASK ASSEMBLY	5
9. ILLUMINATION	6
10. R-F AND OSCILLATOR UNITS	6
11. I-F TRANSFORMER, C-W OSCILLATOR AND CRYSTAL FILTER	8

SECTION II—EMPLOYMENT

12. INSTALLATION	11
<i>a. Unpacking</i>	11
<i>b. Mounting</i>	11
<i>c. Power Connections</i>	12
<i>d. Transmitter Connections</i>	12
<i>e. Output Connections</i>	12
<i>f. Bonding and Shielding</i>	12
<i>g. Mounting of Receiver</i>	12
<i>h. Safety Wire</i>	12
<i>i. Ground</i>	12
<i>j. Antenna</i>	12
13. PREPARATION FOR USE	13
14. OPERATION	13
<i>a. Power Switch</i>	13
<i>b. Operating Test</i>	13
<i>c. Operating Routine</i>	14

SECTION III—DETAILED FUNCTIONING OF PARTS

15. CIRCUITS	17
16. FREQUENCY RANGE AND FREQUENCY BANDS	17
17. INPUT COUPLING	17
18. INPUT PROTECTION	17
19. RADIO FREQUENCY AMPLIFIER	17
20. FIRST DETECTOR	17
21. HETERODYNE OSCILLATOR	17
22. INTERMEDIATE FREQUENCY AMPLIFIER	18
23. C-W OSCILLATOR	19

TABLE OF CONTENTS (Continued)

<i>Paragraph</i>	<i>Page</i>
24. CRYSTAL BAND-PASS FILTER	21
25. SECOND DETECTOR AND AUTOMATIC VOLUME CONTROL	23
26. OUTPUT	23
<i>a. Description</i>	23
<i>b. Noise Compensator</i>	24
27. DYNAMOTOR	24
28. CHARACTERISTICS OF TUBES, LAMPS, VOLTAGE REGULATOR AND FUSE	25

SECTION IV—MAINTENANCE

29. INSPECTION	27
30. CARE AND SERVICING OF DYNAMOTOR	27
31. REMOVAL OF FRONT PANEL	29
32. DIAL AND MASK ASSEMBLY	30
33. REMOVAL AND REPLACEMENT OF DIAL MECHANISM	31
34. REMOVAL OF ANTENNA, R-F, DETECTOR AND OSCILLATOR UNITS	32
35. TROUBLE LOCATION AND REMEDY	33
<i>a. General</i>	33
<i>b. Equipment Required</i>	34
<i>c. Weak or No Signals on All Bands, Modulated Reception</i>	35
<i>d. Weak or No Signals on Any Band, Modulated Reception</i>	39
<i>e. Weak or No Signals on All Bands, C-W Reception (Modulated Reception Normal)</i>	40
<i>f. Measurements with Test Set I-56-C</i>	40
<i>g. Failure of Dial Lights</i>	44
<i>h. Performance Characteristics</i>	45

SECTION V—APPENDIX

36. TABLE OF REPLACEABLE PARTS	47
37. LIST OF MANUFACTURERS	69

LIST OF ILLUSTRATIONS

<i>Figure</i>	<i>Page</i>
1. Radio Receiver.....	1
2. Bottom and Back View of Cabinet	2
3. Mounting Base.....	3
4. Plug PL-Q103 With Terminal Receptacle Disassembled.....	4
5. Plug PL-P103 With Terminal Receptacle Assembled.....	4
6. Chassis, Panel Removed.....	5
7. Rear View, Detail of Precision Dial Mechanism	6
8. Top View of Chassis.....	7
9. Bottom View of Chassis.....	9
10. Plug and Cable Connections	11
11. Antenna Unit	18
12. R-F Unit	19
13. Detector Unit	20
14. Oscillator Unit	21
15. Detail of Bleeder Circuit, C-W Oscillator Switching and A-V-C Time Constant	22
16. Crystal Filter Circuit	22
17. Load Compensator, Bleeder Circuit and Noise Compensator	23
18. Dynamotor	24
19. Bottom View of Dynamotor Showing Filter Open.....	28
20. Dynamotor Filter Wiring Diagram.....	29
21. Dynamotor Disassembled.....	30
22. Detail of Tube Shelf Arrangement Looking Through Panel Opening, Cover Removed	33
23. Trouble Location and Correction Chart (Numerals Refer to Pertinent Paragraphs)	34
24. Chart of Socket and Dynamotor Voltages	35
25. Intermediate Frequency C-W Oscillator Coil and Crystal of Filter Assembly	36
26. Rear View of Chassis.....	39
27. Resistor Boards, Front View	41
28. Resistor Boards, Rear View	41
29. Schematic Diagram.....	70
30. Wiring Diagram	71
31. Tube Shelf Wiring Diagram (For External Connections See Fig. 30)	72
32. Antenna Unit Wiring Diagram (See Fig. 30)	72
33. R-F Unit Wiring Diagram (See Fig. 30)	73
34. Detector Unit Wiring Diagram (See Fig. 30)	73
35. Oscillator Unit Wiring Diagram.....	74
36. Crystal Filter Wiring Diagram	74
37. Wiring Diagram C-W Oscillator Assembly	75
38. Drilling Plan for Mounting Base.....	75
39. Wiring Diagram, Intermediate Frequency Transformers	76
40. Wiring Diagram, Resistor Boards	77
41. Detail Views, Top, Panel and Bottom.....	78
42. Details of Precision Dial Mechanism and Mask Assembly	79
43. Dimensional Views and Cable Plug Details.....	80

INSTRUCTION BOOK FOR OPERATION AND MAINTENANCE OF

Pars. 1-2

RADIO RECEIVER BC-348-E
RADIO RECEIVER BC-348-M
RADIO RECEIVER BC-348-P

SECTION I GENERAL DESCRIPTION



FIGURE 1—RADIO RECEIVER

1. GENERAL

Radio Receiver BC-348-E, Radio Receiver BC-348-M and Radio Receiver BC-348-P are identical both electrically and mechanically.

Each radio receiver is a locally controlled, 8 tube, 6 band superheterodyne receiver intended for use in U. S. Army Aircraft, and covers the frequency ranges 200 to 500 kilocycles and 1.5 to 18 megacycles. These receivers are not intended for remote control, and no features or units have been provided for remote operation. They are capable of voice, tone or c-w reception with manual or automatic volume control. When equipped with

tubes, dial lights and fuses, and with the antenna, ground and primary power source connections properly made, these receivers become complete and operative equipments by the addition of headsets, as all coils and the high-voltage power supply units are contained within the receivers. The total power consumed by these receivers is 56 watts from a 28 volt d-c source.

2. COMPONENT UNITS

The following is a list of the component units of these receivers:

GENERAL DESCRIPTION

Quantity	Component	Dimensions (Inches)	Weight (Lbs.)
1	Fuse FU-35	1 1/4 x 1/4 dia.	0.008
2	Lamp LM-27, each	1 1/8 x 3/8 dia.	0.005
1	Mounting (not including plugs PL-P103 or PL-Q103)	1 7/16 x 8 9/16 x 18 1/16	4.1
1	Plug PL-P103 (straight)	1 5/8 x 2 5/32 x 2 31/32	0.34
1	Plug PL-Q103 (angle)	1 5/8 x 2 5/32 x 3 31/32	0.41
1	Radio Receiver (including Dynamotor and Mounting and equipped with all accessory components except headphones)	10 7/16 x 9 9/16 x 18	39.6
1	Tube VT-48	4 3/16 x 1 9/16 dia.	0.08
1	Tube VT-65	2 5/8 x 1 5/8 dia.	0.06
1	Tube VT-70	4 17/32 x 1 9/16 dia.	0.09
3	Tube VT-86, each	3 1/8 x 1 5/8 dia.	0.07
1	Tube VT-91	3 1/8 x 1 5/8 dia.	0.07
1	Tube VT-93	3 1/8 x 1 5/8 dia.	0.07
1	Voltage Reg., RCA 991	1 7/16 x 5/8 dia.	0.014

Total weight 44.917

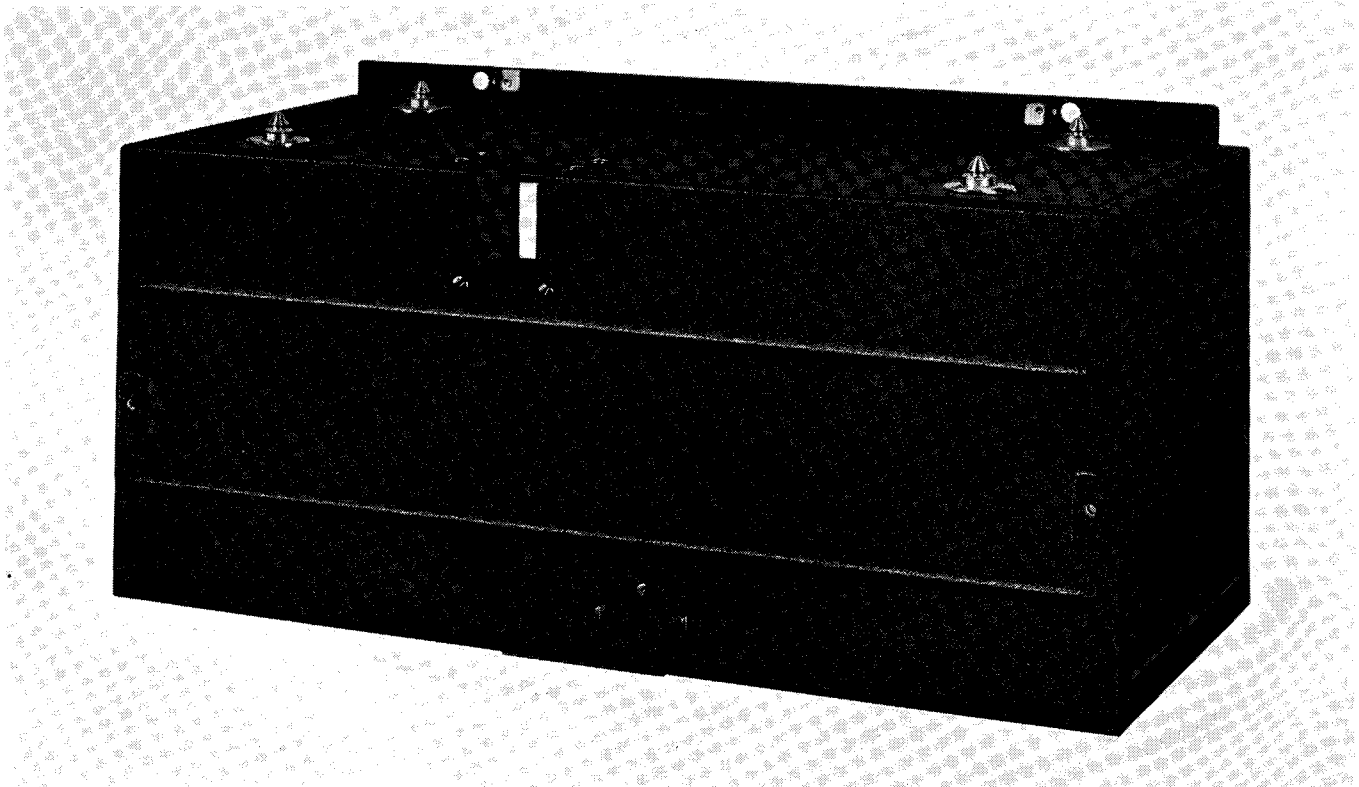

FIGURE 2—BOTTOM AND BACK VIEW OF CABINET

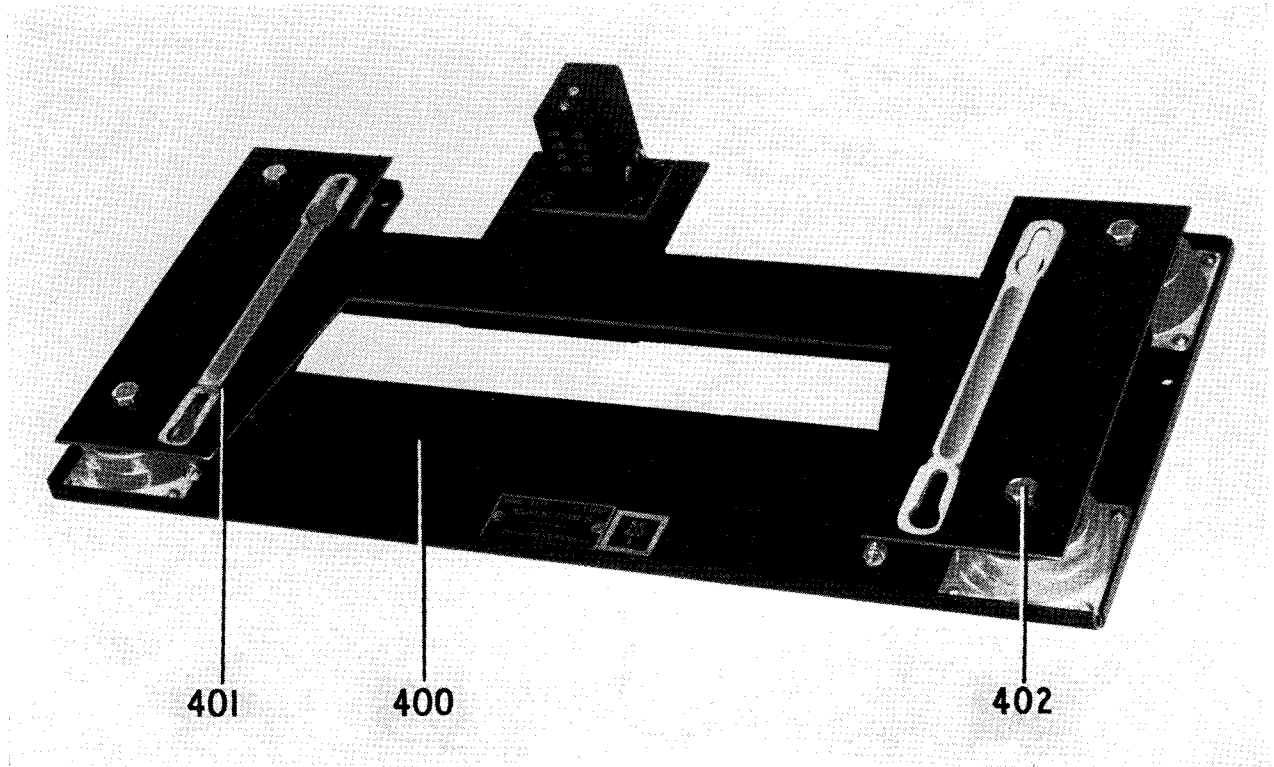

FIGURE 3—MOUNTING BASE

3. CABINET

The receiver cabinet is of spot-welded aluminum construction with black wrinkle finish, and is embossed on top and back to add rigidity and strength. The panel (front) end allows the removal of the receiver chassis which runs on the stainless steel strips mounted in the end corners of the cabinet. Two tapped inserts are placed in the rear to receive the thumb screw rods which secure the chassis in the cabinet. A cutout in the rear bottom permits the entrance of Plug PL-P103 or PL-Q103. An aluminum casting is mounted over this cutout and acts as a seal between the cabinet and the chassis. The bottom of the cabinet is reinforced by a stainless steel plate to which are attached the four mounting studs for securing the cabinet to mounting. Two snap slides are mounted on the downward projection of the front of the stainless steel plate.

4. MOUNTING FT-154-E, FT-154-P or FT-154-W

The mounting is constructed of stainless steel except for the aluminum base which carries the mounting holes and to which are attached the bases of four shock absorbers. To the top of the shock absorbers is fastened the stainless steel support, which provides for the attachment of the receiver cabinet by means of studs and snap-slides. Grooves are provided in the stainless steel support to facilitate the engagement of the studs of the cabinet with the mounting.

5. PLUG PL-P103 AND PL-Q103

The plug, attached to the mounting by screws, is provided with eight terminals which are accessible upon removal of the rear cover of the plug housing. The plug, when provided with a straight outlet, becomes Plug PL-P103. A right

GENERAL DESCRIPTION

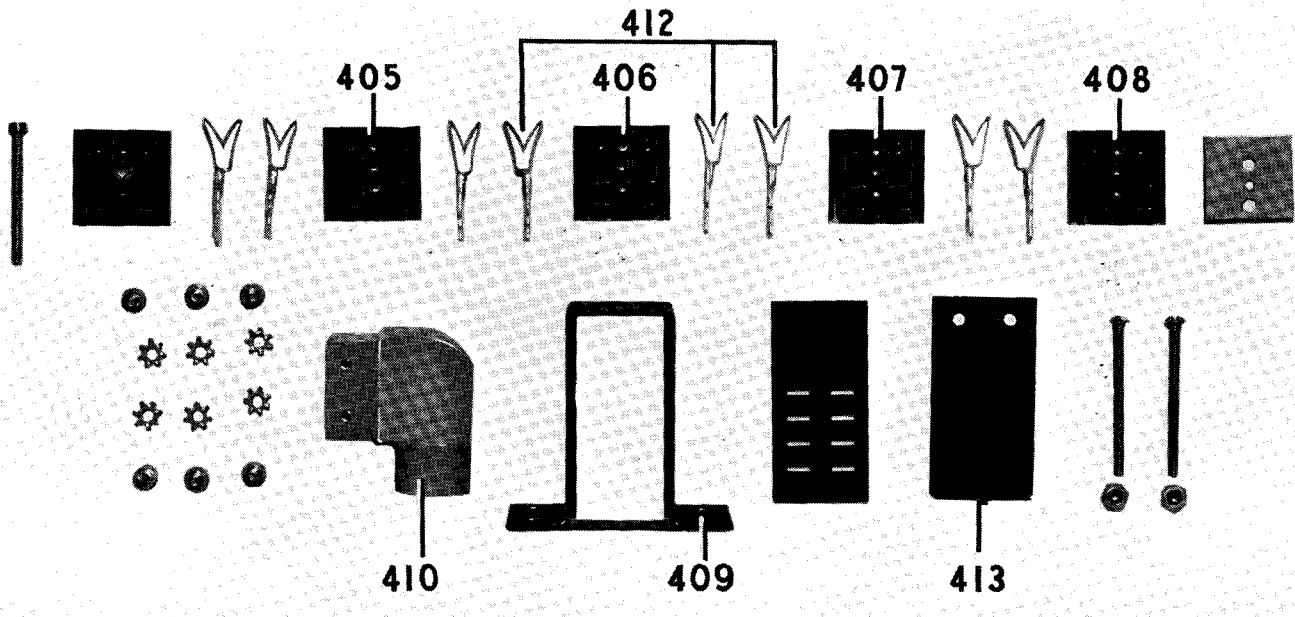

FIGURE 4—PLUG PL-Q103 WITH TERMINAL RECEPTACLE DISASSEMBLED

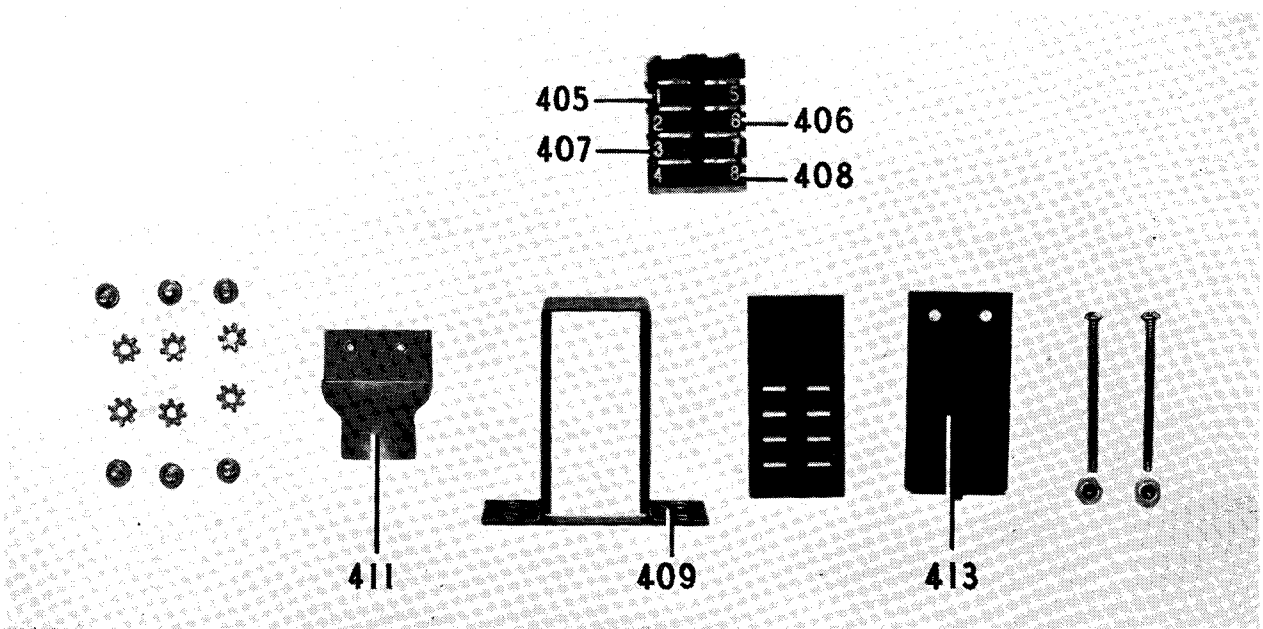

FIGURE 5—PLUG PL-P103 WITH TERMINAL RECEPTACLE ASSEMBLED

angle outlet which may be mounted so as to join the cable in any of three horizontal positions, to the right, left or back of the receiver, may be used with the plug, making it Plug PL-Q103.

6. CHASSIS

The chassis consists of an aluminum casting mounted between two end plates of sheet aluminum which serve as runners and guides when placing the chassis in the cabinet. The end plates are provided with cutouts to facilitate servicing.

7. PANEL

The front panel is attached to the chassis and to the front end plates by screws. Two handles are mounted on the panel. Two thumb-screw

rods secure the chassis in the cabinet and pass through a cutout covered by a plate which is provided to give access to the wiring under the r-tube shelf for servicing and maintenance. The following panel items are mounted on the front of the panel:

Antenna and ground binding posts; antenna alignment control; dial light rheostat control; tuning control; band switch control; dial window housing which covers the dial lights; beat frequency control; crystal filter control; volume control; AVC-OFF-MVC control; C-W OSC. control; and two telephone jacks.

8. DIAL AND MASK ASSEMBLY

The dial and mask assembly is mounted on an aluminum casting which carries the gearing of

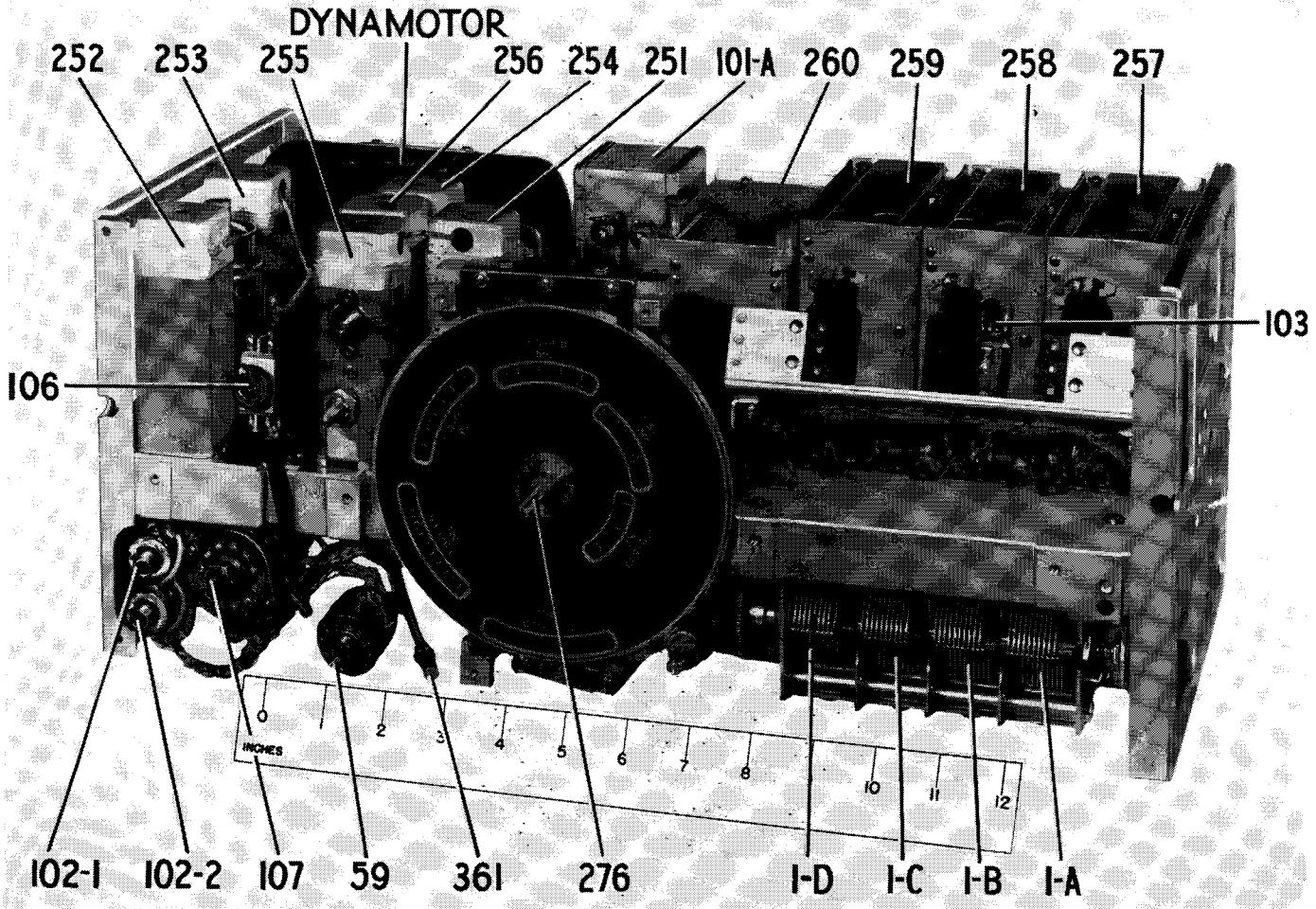

FIGURE 6—CHASSIS, PANEL REMOVED

GENERAL DESCRIPTION

the tuning condenser drive and the detent. This unit is attached to the front panel and connects to the band switch drive shaft through a coupling of the Oldham type. The dial is divided into six frequency bands and the dial and tuning condenser are so geared to the tuning control shaft that the tuning condenser covers the frequency range indicated on the dial for each band in approximately 90 revolutions of the tuning knob. Split gearing is used extensively to minimize backlash. A positive stop is provided to prevent undue pressure on the gears and to limit the travel of the dial and tuning condenser. A mask, with suitably located and marked windows, is mounted before the dial. The mask is controlled by the band change switch and is positioned by the star detent.

9. ILLUMINATION

The receiver tuning dial is illuminated by means of two dial lights (Lamp LM-27) whose brilliancy is controlled by the DIAL LIGHTS rheostat. This rheostat has an off position for use when the illumination is not desired. The dial lights are located beneath a readily removable housing which permits the easy replacement of a dial lamp during flight.

10. R-F AND OSCILLATOR UNITS

The antenna, r-f, 1st detector and oscillator sub-assemblies are mounted on the right rear portion of the chassis. Each sub-assembly consists of the r-f coils, trimmers and band switch wafers

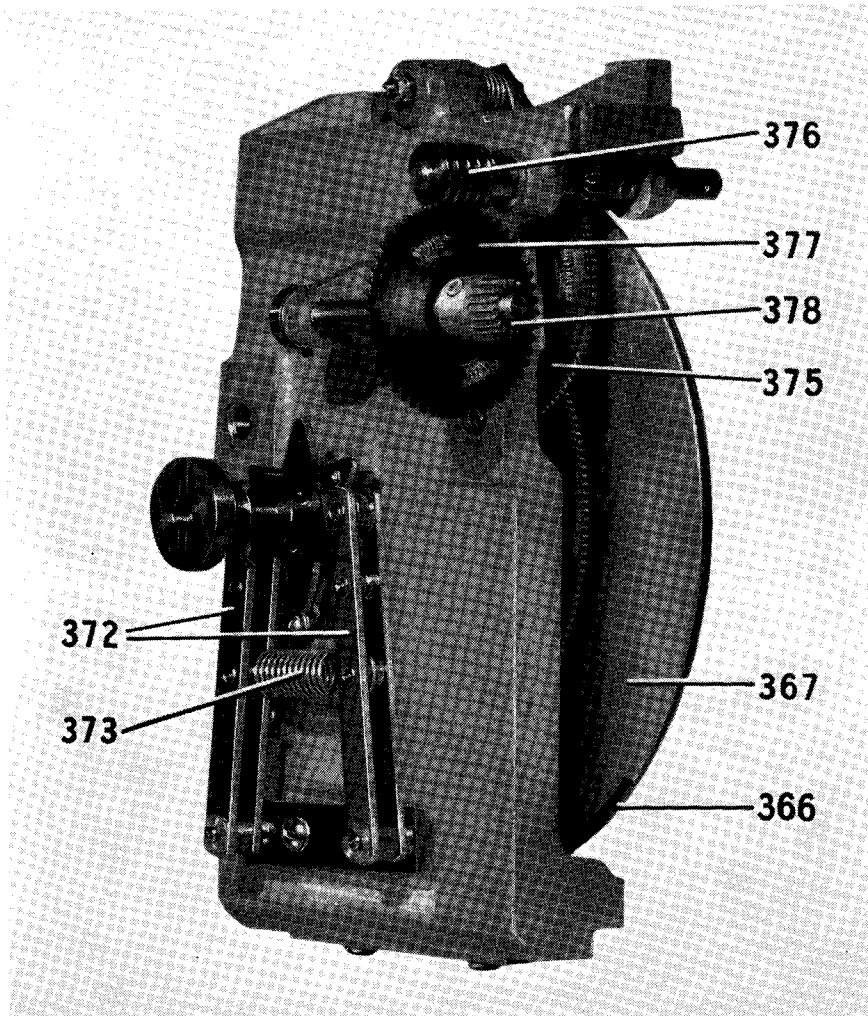

FIGURE 7—REAR VIEW, DETAIL OF PRECISION DIAL MECHANISM

3rd I. F. TRANSFORMER
SECONDARY ADJUSTING SCREW

3rd I. F.
2nd DET.
VT 93

4th I. F. TRANSFORMER
PRIMARY ADJUSTING SCREW

VT 48
OUTPUT

BAND ALIGNMENT TRIMMERS

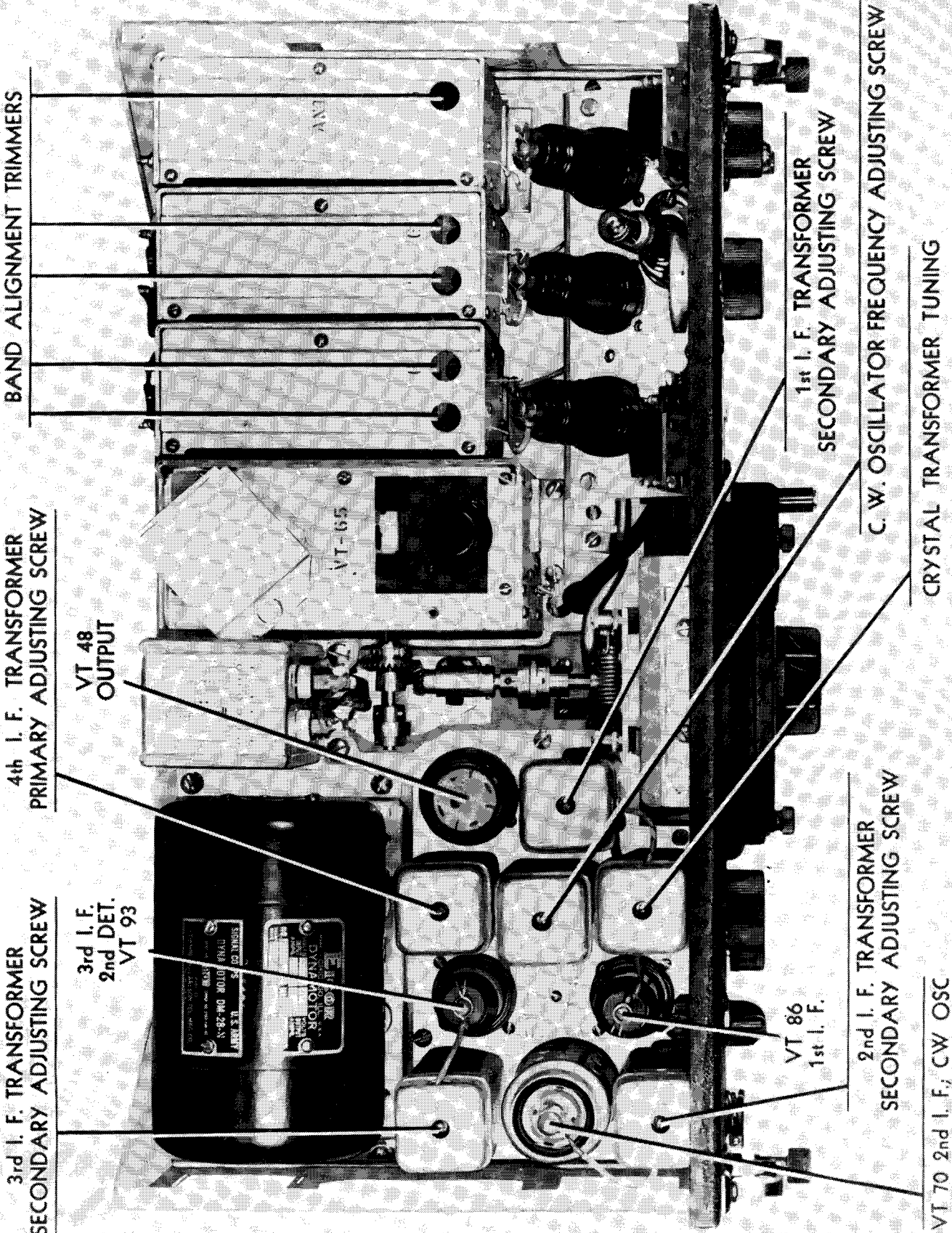

VT 86
1st I. F.

2nd I. F. TRANSFORMER
SECONDARY ADJUSTING SCREW

1st I. F. TRANSFORMER
SECONDARY ADJUSTING SCREW

C. W. OSCILLATOR FREQUENCY ADJUSTING SCREW

CRYSTAL TRANSFORMER TUNING

VT 70 2nd I. F.; CW OSC

FIGURE 8—TOP VIEW OF CHASSIS

with the necessary fixed capacitors and resistors. Passing through all of these sub-assemblies is the band switch drive shaft which is pulled out from the right end of the receiver chassis before a sub-assembly is removed.

Three grounding straps are provided for the purpose of bonding the antenna unit, r-f unit, and the oscillator unit cans to the tuning condenser.

11. I-F TRANSFORMER, C-W OSCILLATOR AND CRYSTAL FILTER

These units are mounted on the left front portion of the chassis. The variable capacitor of the c-w oscillator is controlled through a flexible shaft terminating in a knob on the front panel.

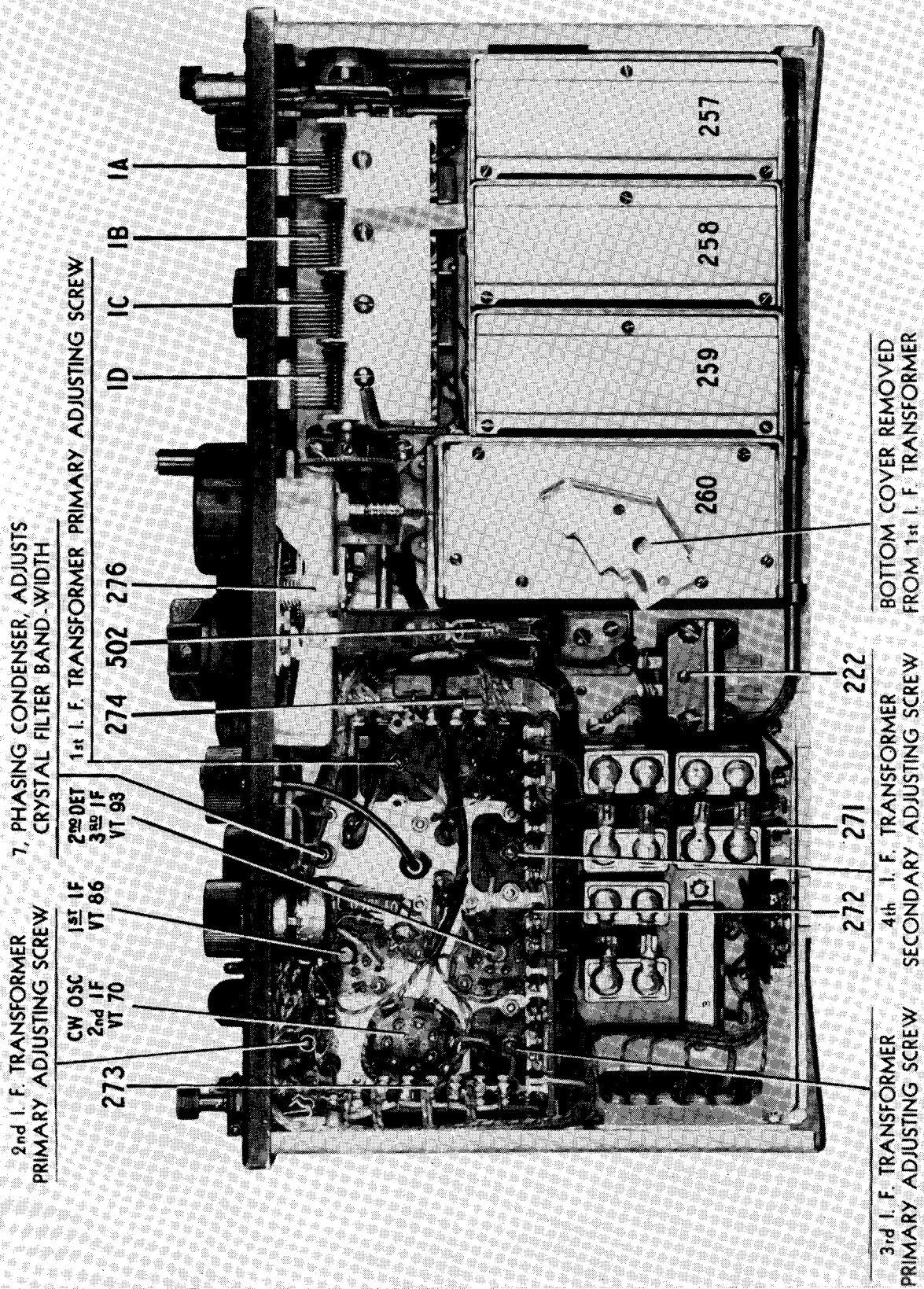

FIGURE 9—BOTTOM VIEW OF CHASSIS

(blank)

10

SECTION II

EMPLOYMENT

NOTE—No attempt at either mechanical or electrical servicing of these receivers should be made except at Signal Corps Repair Shops and Signal Corps Radio Sections (or Signal Sections) at Air Depots, unless suitable shop and testing facilities are available and authority to repair has been granted by the Corps Area Signal Officer. A standard signal generator, a phantom antenna, Test Set I-56-C, and other like equipment should be used for alignment purposes and instructions in this book carefully followed.

12. INSTALLATION

The most important considerations necessary for the successful installation and operation of this receiver are as follows:

a. Unpacking

Carefully open the packing box and remove the cardboard cartons which it contains. Open each of these cardboard containers; one contains the receiver in its cabinet; the other holds the mounting base assembly. Take the receiver chassis from the metal cabinet and remove the cardboard reinforcing material which is packed around the dynamotor. Clean the receiver of any surplus packing material or dust, replace it within the metal cabinet, and put the cabinet upon the mounting base assembly.

b. Mounting

The receiver should be mounted on a plane surface with sufficient clearance being al-

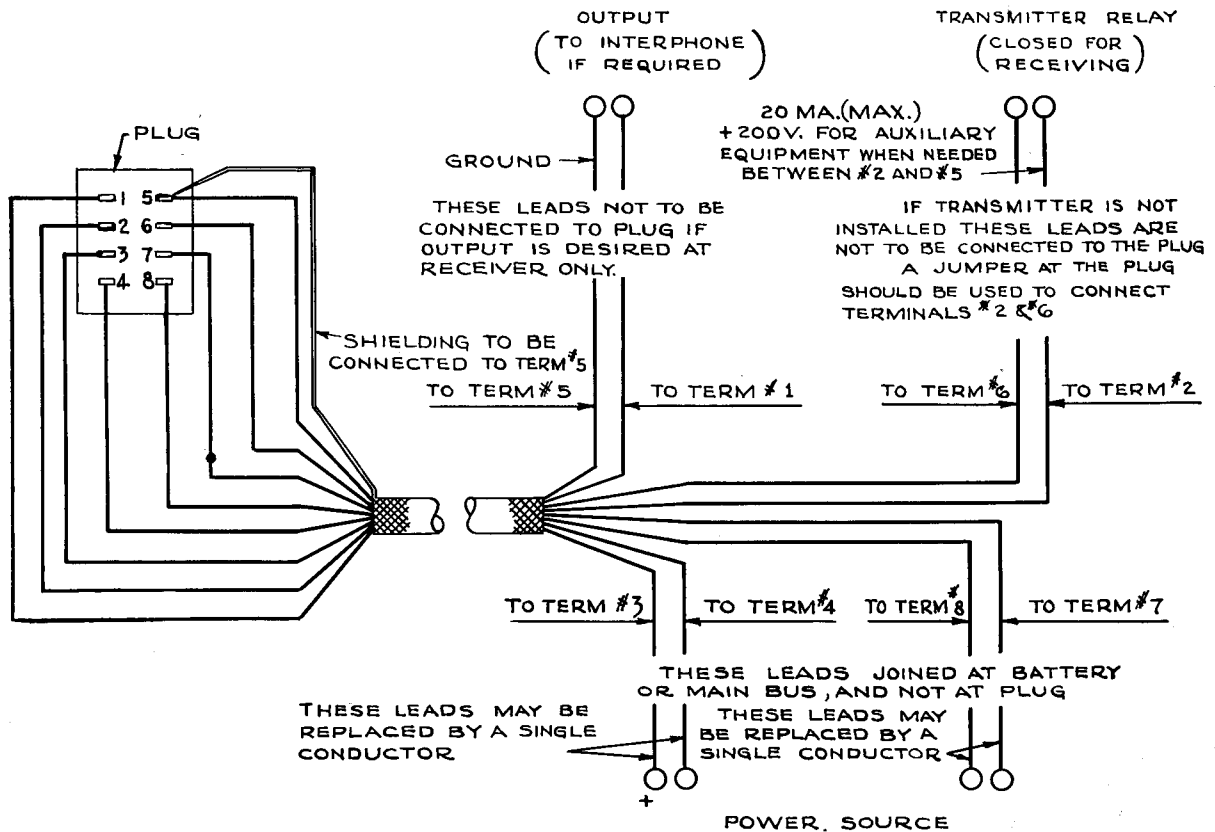

FIGURE 10—PLUG AND CABLE CONNECTIONS

lowed on all sides to permit free action of the shock absorber mounting. The mounting should be permanently attached to the rigid members of the plane. The drilling plan of the mounting is shown in Section V, Figure 38.

c. Power Connections

The leads to the primary power source are connected as shown in Figure 10. The parallel connected lead from plug terminals 3 and 4 may be replaced by a single conductor of cross section equivalent to the two separate leads. Similarly, the parallel connected leads from plug terminals 7 and 8 may be replaced by a single conductor of equivalent cross sectional area. The power source to which these leads are connected should be 28 volts d-c for this equipment.

d. Transmitter Connections

Provisions have been made for the protection of these receivers when the associated transmitter is being used. Leads from plug terminals 2 and 6 should be wired to contacts on the transmitter relay. If the transmitter is removed from the installation, or if these receivers are being installed without an associated transmitter, the wires from plug terminals 2 and 6 must be connected together to have the receivers operate.

e. Output Connections

The output of this receiver has been brought to plug terminals 1 and 5 and to the two front-panel jacks. Leads from these terminals should be wired to the interphone system or as otherwise desired. If the output is desired only at the receiver, it should be taken directly from the phone jacks and no connections made to plug terminals 1 and 5. The output transformer has two output impedances available at its terminals. These are terminal #5 for high (4000 ohm) impedance output, or terminal #6 for low (300 ohm) impedance connection. These terminals are marked both with numbers, and with the designation HI and LO on the transformer terminal board, and a detailed connection diagram on the top of the transformer shows that the green lead of the audio jack is shifted between these terminals according to the output impedance desired.

f. Bonding and Shielding

At the time of installation of this equipment, care should be taken to insure that the engine ignition system, generator, and other possible causes of disturbance are properly shielded and that bonding of metal parts is or has been carefully carried out.

g. Mounting of Receiver

When proper wiring connections have been made, place the receiver on its mounting with the studs on the bottom of the cabinet entering the slots of the mounting. See that the cabinet is well down on the mounting and that all four studs are fully seated, then push the cabinet towards the rear and secure in place by the snapsides on the lower front corners of the cabinet.

h. Safety Wire

Safety wire should be passed through the holes of the snapslide assemblies, care being taken that the wires are not twisted too tightly.

i. Ground

The ground binding post "G" should be connected by a short, direct, low resistance lead to some grounded metal portion of the plane and soldered at the point, if practicable. The lead should have enough slack to prevent vibration being transmitted to the receiver.

j. Antenna

The antenna circuit aligning capacitor is such that the antenna circuit can be properly aligned when using antennas that range in effective capacitance from 50 to 200 micro-microfarads. However, satisfactory performance will be obtained on practically any type of mast, fixed, or trailing wire antenna, although in extreme cases, that is, very short mast or very long trailing wire, the most favorable setting of the antenna alignment control may not be obtained. In general, the most effective antenna is one whose length away from the grounded metal fuselage is the greatest. The receiver should be located as near as possible to the lead-in insulator and connected from the insulator to the antenna binding post A by a copper wire. The lead should have enough slack

to prevent vibration being transmitted to the receiver.

13. PREPARATION FOR USE

These receivers are self-contained units, having their high voltage power supply and all coil sets built in. *Before installing the tubes they should be checked with the required tube checker. Be sure that the proper tubes, well pushed down and firmly seated in their sockets, are installed, that the tube shield is properly seated, and that grid caps fit tightly on the tubes.*

Check dial lights and fuse and see that they are properly and securely placed. Make sure that the leads to the dynamotor unit are properly connected at the dynamotor terminal strip and that the screws holding them in place are tight. Place the receiver AVC-OFF-MVC switch in the MVC position, and the band switch on band 2. By means of the tuning control, tune in a signal at approximately 3.4 megacycles, to maximum signal strength. Reduce volume by means of volume control knob until signal is just audible. Readjust the tuning control to secure any additional increase possible. Adjust the antenna alignment control to give maximum volume.

14. OPERATION

a. Power Switch

Power to the receiver is controlled by the receiver AVC-OFF-MVC switch. With this switch in the OFF position, no power is supplied to the receiver. When switched to either the MVC or AVC position, power from the primary source is supplied to the tube heaters and dynamotor placing the equipment in operation. The screen grid voltage supply leads are carried out of the receiver through the power plug to the keying relay of the associated transmitter where the circuit is opened when actually transmitting (Refer to Paragraph 12d).

b. Operating Test

When the receiver has been completely installed, an operating test should be made as follows:

- (1) Plug a headset into one of the jacks marked TEL. Set receiver switch to MVC. The dynamotor should start and

after the tubes have warmed up (approximately 30 seconds), the volume control knob should be advanced until a slight background noise is heard. Set band switch to the frequency band in which test signals are available.

- (2) Using the tuning knob and with reference to the calibrated scale on the dial, tune in the desired signal. NOTE:—*All tuning should be done on MVC with the volume control advanced only enough to give the desired signal strength. In the absence of a signal the setting of the volume control can be judged by the loudness of the background noise. On MVC, with the volume control set at maximum, very strong carrier waves will block the receiver and intelligible signals cannot be received.*
- (3) Set the receiver switch to AVC. The desired signal should still be heard.
- (4) With the beat frequency adjustment at zero beat position (arrow on knob pointing up), turn the c-w oscillator switch to the position ON. An audible beatnote should be heard which should vary in pitch when the beat frequency adjustment is changed.
- (5) With the c-w oscillator still ON, throw the crystal filter switch to IN. Noise should be greatly reduced and the signal can be tuned out by a much smaller movement of the tuning control knob than when the crystal filter switch is in the OUT position.
- (6) Turn the dial light rheostat and observe if control of illumination is secured with both dial lights functioning.
- (7) A check should be made before flight and with the airplane engine running. An increase of background noise when the engine starts, indicates imperfect shielding, bonding, faulty generator regulator, faulty generator, open filter capacitors, or a combination of these faults.
- (8) Always turn the receiver switch to the OFF position when the receiver is not to be used.

c. Operating Routine**(1) CONTROLS****(a) A and G**

The antenna is connected to the binding post marked A, and the ground lead to the binding post marked G.

(b) ANT. ALIGN.

This control varies a capacitor for aligning the input circuit to a given antenna. This adjustment should be made with the receiver tuned to approximately 3.4 megacycles.

(c) TUNING

This control varies the setting of the 4-gang variable tuning capacitor.

(d) BAND SWITCH

This control selects the desired frequency band as indicated on the dial mask.

(e) DIAL LIGHTS

This knob controls the intensity of dial illumination and is provided with an OFF position.

(f) C-W OSC. ON-OFF

This toggle switch controls the operation of the c-w oscillator as well as the a-v-c time constant for c-w reception.

(g) CRYSTAL OUT-IN

This control permits the insertion of an i-f crystal filter when extreme selectivity is desired.

(h) BEAT FREQ.

This control permits vernier adjustment of the c-w oscillator frequency and in tuning it should be set near the zero beat position (arrow on knob pointing up).

(i) INCREASE VOL.

This control is for sensitivity adjustment on MVC operation and output level

adjustment on AVC operation. When switching from MVC to AVC or vice versa, it will generally be necessary to readjust this control to maintain a given volume level as only under certain conditions of signal strength will the volume level remain unchanged.

(j) AVC-OFF-MVC

This three-position switch in the OFF position removes all power from the receiver. In the MVC position the receiver is operative with manual volume control, while in the AVC position the automatic volume control is functioning.

(k) TEL.

These are open circuit jacks providing connections to the headset.

(2) MODULATED SIGNAL RECEPTION

(a) Throw the AVC-OFF-MVC switch to MVC and set other switches and controls as follows:

C-W OSC - OFF
CRYSTAL - OUT

ANTENNA ALIGNMENT

—Adjust control to give maximum volume.

(b) Set the band switch to the desired frequency band and adjust the tuning control to the desired frequency. It is of great importance that this tuning be accomplished with the receiver switch in the MVC position.

NOTE: *The AVC position should not be employed while tuning in a signal. Tuning should always be done in the MVC position and with the volume control advanced only as far as required for a comfortable output level.*

(c) Increase the volume control until the desired signal is heard or the background noise attains a fair level.

(d) Adjust the tuning control until maximum output from the desired signal is obtained. This insures correct alignment or proper tuning of the receiver.

(e) If automatic volume control is desired, switch to the AVC position and readjust the volume control for the desired output level.

(3) C-W RECEPTION

(a) The procedure is the same as outlined above with the exception that the c-w oscillator switch is ON and tuning accomplished with the beat frequency control set near the zero beat position (arrow on knob pointing up).

(b) After tuning in the desired signal the beat frequency control may be varied

and the frequency of the beat note adjusted as desired.

(c) Automatic volume control may be employed for c-w reception by switching to the AVC position and readjusting the volume control.

(d) When extreme selectivity is desired to minimize interference, the crystal filter is switched IN. A slight readjustment of the tuning, beat frequency and volume controls may be required to secure the desired beatnote frequency and volume level.

NOTE: The crystal band pass filter is intended primarily for use in c-w reception. However, the added selectivity may at times prove helpful in receiving modulated signals through heavy interference.

(BLANK)

16

SECTION III

DETAILED FUNCTIONING OF PARTS

15. CIRCUITS

Electrically the receiver comprises two stages of tuned radio frequency amplification preceding the first detector, a temperature compensated heterodyne oscillator, three intermediate frequency amplifier stages, a second detector and one stage of audio-frequency amplification with a transformer output circuit. A crystal band-pass filter and beat-frequency oscillator are also included. The former is for increasing selectivity and the latter for receiving c-w signals. The schematic and wiring diagrams are shown in Figures 29 and 30, in Section V.

16. FREQUENCY RANGE AND FREQUENCY BANDS

The frequency ranges of 200 to 500 kilocycles and 1.5 to 18.0 megacycles are covered in six bands which are under the control of a band change switch. The frequency range for each of the six bands is given in the following table:

Band	Frequency Range
1	200 to 500 kc
2	1.5 to 3.5 mc
3	3.5 to 6.0 mc
4	6.0 to 9.5 mc
5	9.5 to 13.5 mc
6	13.5 to 18.0 mc

17. INPUT COUPLING

The antenna input circuit is capacitively coupled to the first tuned grid circuit by means of the antenna alignment capacitor. Sufficient range is available in this capacitor to permit alignment for antenna capacities within the limits of 50 to 200 micromicrofarads. The antenna input circuit is designed for antennas with resistances between 1 and 75 ohms.

18. INPUT PROTECTION

The resistor 50-1 provides a leakage path for static charges which may be collected on the antenna. The input circuit will withstand the application of 250 volts direct current without damage. For protection against the application

of radio frequency voltages up to 30 volts rms, the input circuit provides for the building up of a protective negative grid bias across the grid filter resistor 48-1, whenever the input signal is sufficient to drive the grid into the positive region, causing grid current to flow. The voltage drop which occurs across the grid filter resistor 48-1 as a result of this grid current flow is additive in effect to the other bias supplied the tube, serving to accommodate extremes of radio frequency input.

19. RADIO FREQUENCY AMPLIFIER

Two stages of tuned radio frequency amplification and a third tuned circuit before the first detector comprise the radio frequency preselection system handling the signal input before delivery to the grid of the first detector. The two r-f amplifiers utilize super-control pentode tubes, Tube VT-86. Separate inductances are employed for each frequency band. The r-f gain of each of the six bands is kept uniform by selection of the turn ratio between the grid and plate circuit for each of the respective bands. A relatively low signal level is maintained at the grid of the first detector tube, thus insuring freedom from cross modulation interference.

20. FIRST DETECTOR

The first detector employs Tube VT-91 which has a sharp cutoff characteristic. The low signal level at the grid of the first detector, together with the r-f preselection, insures a minimum of undesired responses. The oscillator output is coupled into the cathode circuit of this tube and separate cathode coupling coils provide optimum oscillator output for each frequency band.

21. HETERODYNE OSCILLATOR

The heterodyne oscillator employs a tuned grid, plate feed-back circuit, utilizing a triode tube, Tube VT-65. The effects of wide variations in ambient temperature under service conditions on the oscillator frequency have been reduced to a minimum by the use of a highly stabilized tuning capacitor and temperature compensation

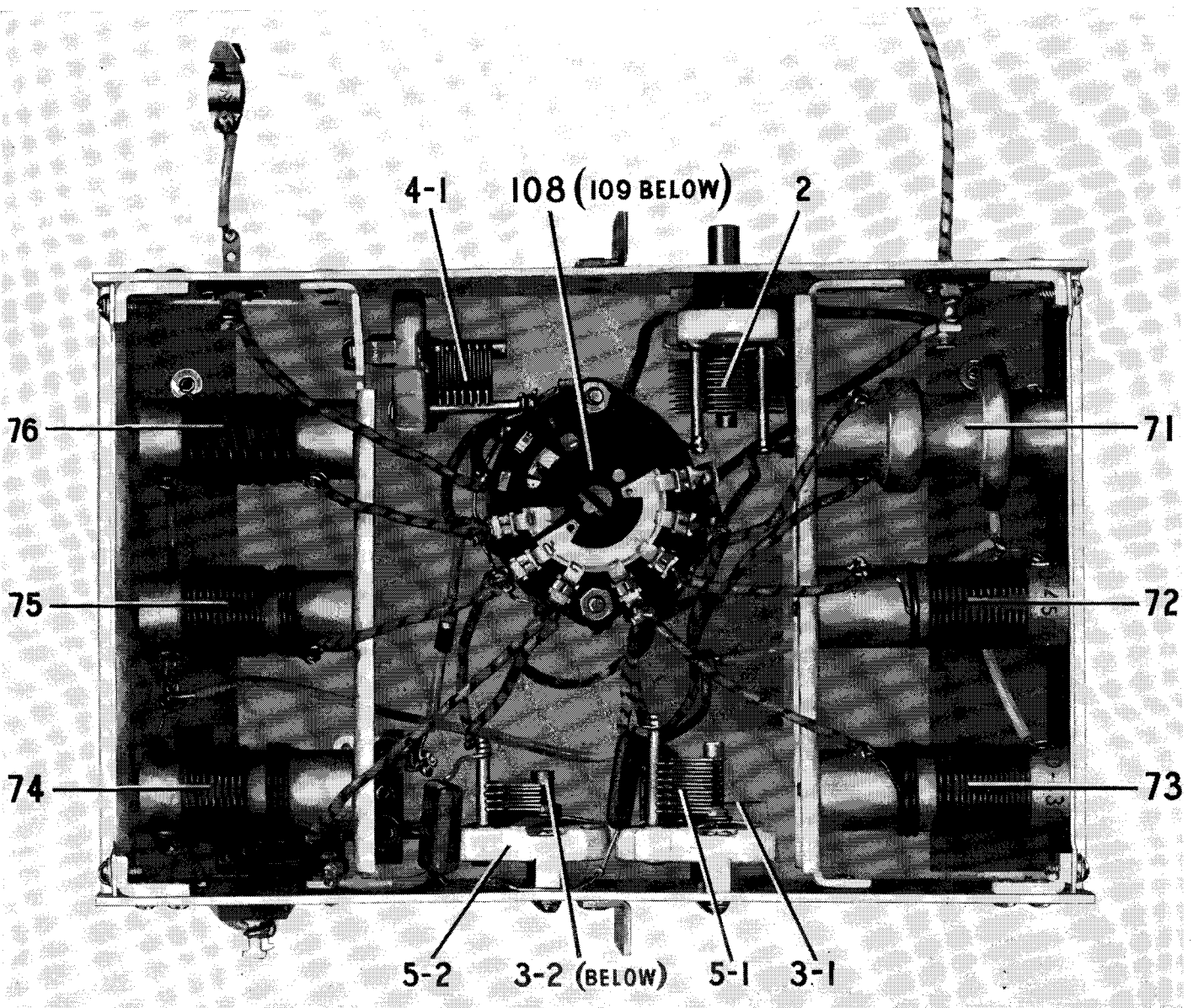

FIGURE 11—ANTENNA UNIT

with ceramic fixed capacitors (33, 34, 35, 36). Individual inductances and trimmers are employed for each frequency band, and the low impedance coupling circuit to the cathode of the first detector insures a freedom from frequency instability with load variation or detector circuit tuning. On the four lower frequency tuning bands, the oscillator frequency is higher than the desired signal by the intermediate frequency. On the two higher frequency ranges, Bands 5 and 6, the oscillator is on the low frequency side of the desired signal.

22. INTERMEDIATE FREQUENCY AMPLIFIER

The intermediate frequency amplifier comprises three low gain amplifying stages coupled by four highly selective, double tuned circuit transformers. The intermediate frequency employed is 915 kc. The i-f transformers are tuned by means of adjustable iron cores and fixed capacitors. The increased permeability resulting from the use of the iron cores contributes largely to the highly selective transformer characteristics while the lowered tuned circuit im-

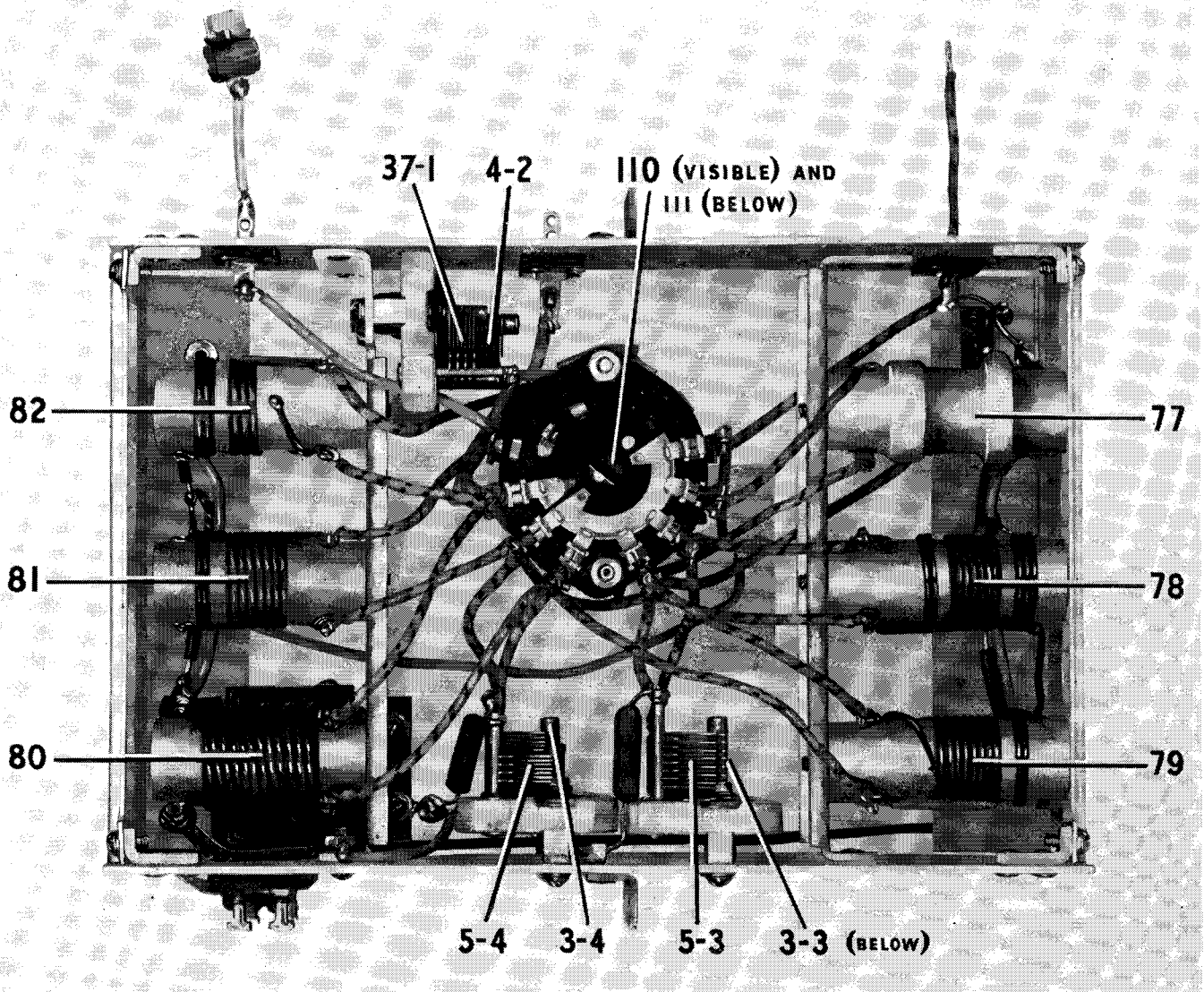

FIGURE 12—R-F UNIT

pedance, secured by the relatively large fixed tuning capacitors, provides an inherently stable amplifier. Tube VT-86 functions as the first i-f amplifier while the pentode section of Tube VT-70 is employed as the second i-f amplifier. Tube VT-93 as the third i-f amplifier supplies a relatively high level signal to the diodes of this same tube.

23. C-W OSCILLATOR

a. The c-w oscillator employs the triode section of Tube VT-70 (second i-f amplifier tube) in a tuned grid plate feed-back circuit. The adjustable iron core in the grid inductance

98 is employed for rough frequency alignment while a panel-operated control permits fine adjustment of the beat frequency within a range approximately 4,000 cycles each side of zero. The effects of ambient temperature variations are minimized by the use of a temperature-compensated tuned circuit. The c-w oscillator operates at an extremely low level, minimizing harmonics and stray oscillator pickup. The output is capacitively coupled to the plate circuit of the second amplifier tube by the coupling lead connected to the oscillator grid. Amplification by the third i-f amplifier stage, the gain of which

DETAILED FUNCTIONING OF PARTS

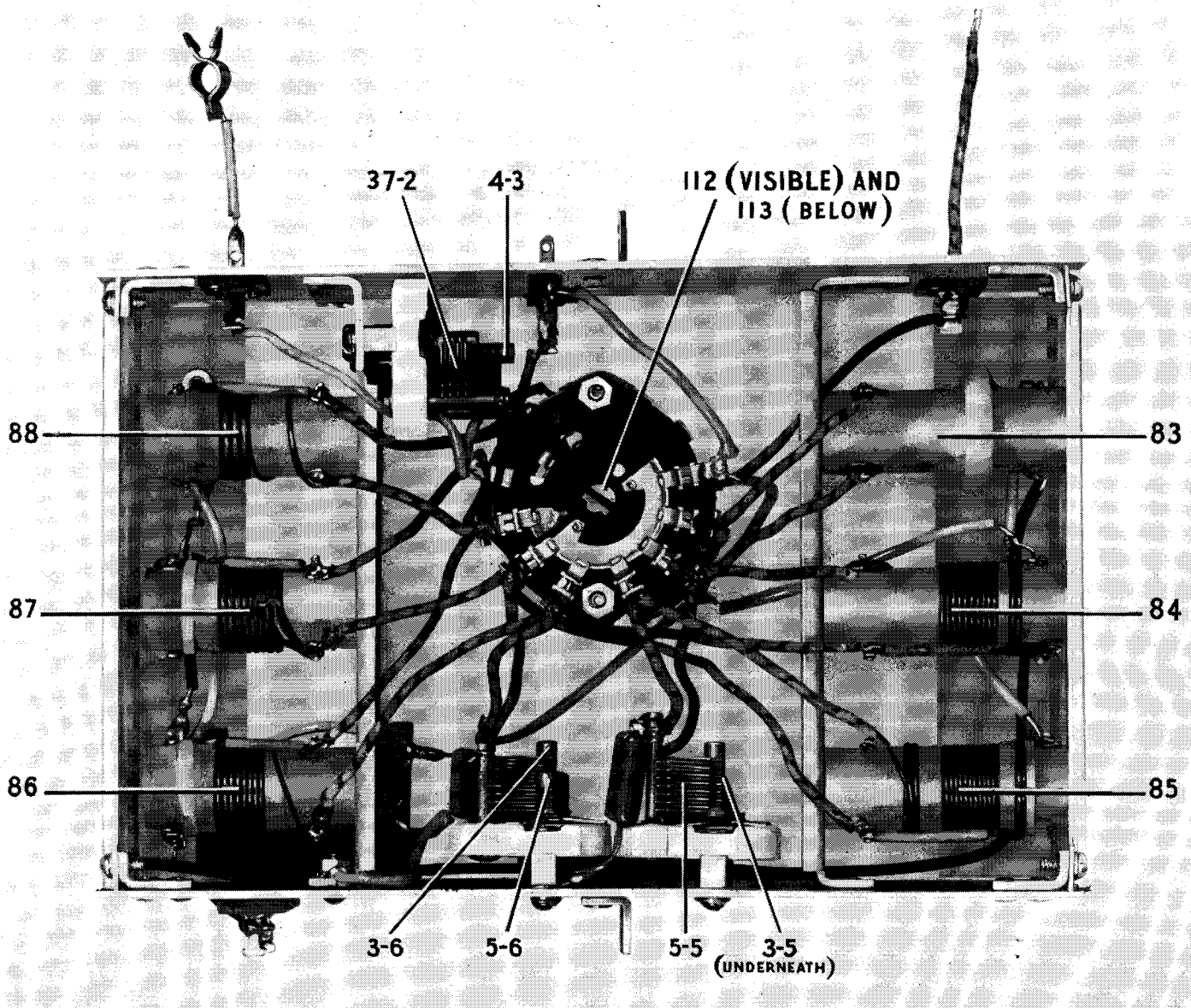

FIGURE 13—DETECTOR UNIT

is not controlled either by manual or a-v-c, provides sufficient output from the c-w oscillator to the diode detector. This value of oscillator output is somewhat below the level at which the a-v-c operates, thus permitting the use of automatic volume control even for c-w reception.

b. The c-w oscillator switch 106 in the ON position supplies the oscillator plate voltage and increases the a-v-c time constant by con-

necting the additional capacitor 101-C. Switch 106 supplies the oscillator plate voltage by connection to the screen grids of the first and second i-f and first r-f tubes. The same switching connects the loading resistor 43-4 which drops the screen voltage to the first and second i-f and first r-f tubes to a value that reduces the sensitivity by an amount sufficient to keep the overall set noise essentially constant. This arrangement for supplying the c-w oscillator has added ad-

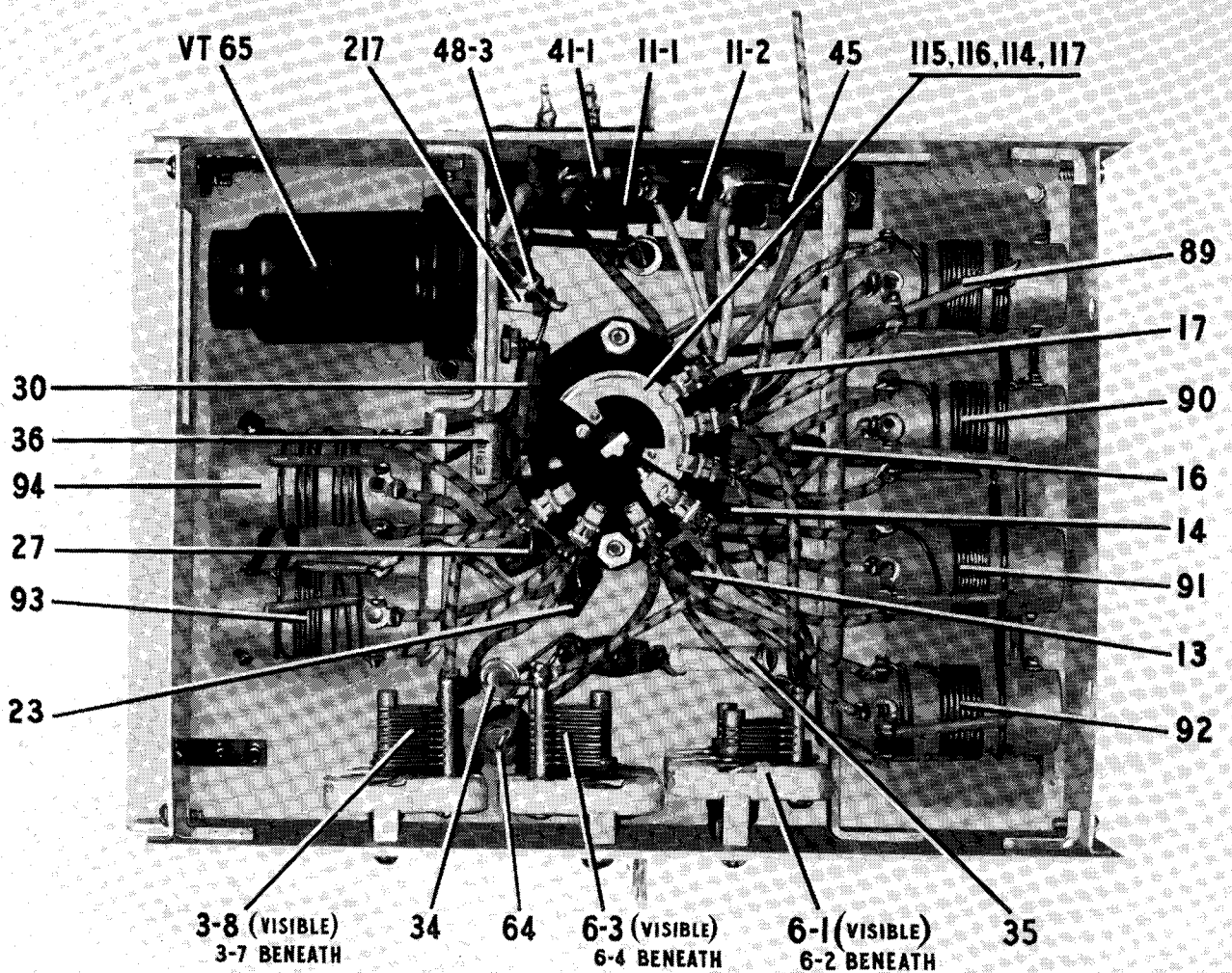

FIGURE 14—OSCILLATOR UNIT

vantages which are not obvious. In order to have sufficient oscillator excitation available to handle high detector levels encountered with a-v-c operation and strong signal inputs, while still keeping the no signal c-w excitation below the a-v-c delay level, it is desirable to have the c-w oscillator output increase as a strong signal input raises the a-v-c bias. This circuit arrangement, as shown in Figure 15, accomplishes this result, since with switch 107 in the a-v-c position, resistors 42-6, 56, 62, and 59-A form a fixed bleeder supplying the screen grid voltage to r-f, 1st detector and i-f tubes. A strong input signal building up the a-v-c bias causes a considerable decrease in screen current

and hence an increase in the screen supply voltage. This increases the voltage supplied to the c-w oscillator and hence the excitation increases in proportion to signal level at the detector.

24. CRYSTAL BAND-PASS FILTER

Additional selectivity is available by the use of the i-f crystal filter preceding the first i-f amplifier tube. This crystal filter comprises a balanced capacity bridge circuit which may be adjusted internally to provide a band width of 800 to 3,000 cycles at 20 decibels down from resonance. The tapped tuned circuit (19 and 96) matches the impedance of the crystal bridge to the 1st i-f grid. The crystal filter may be switched

DETAILED FUNCTIONING OF PARTS

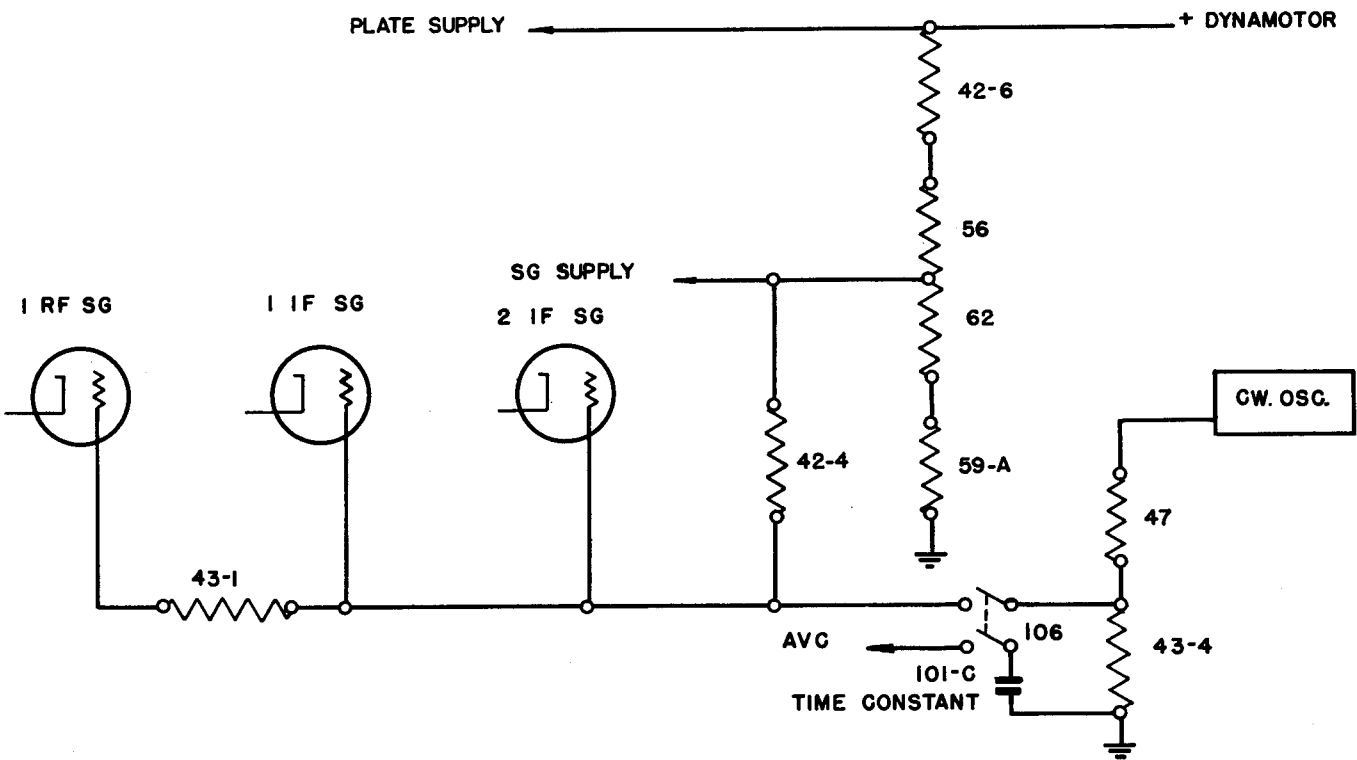

FIGURE 15—DETAIL OF BLEEDER CIRCUIT, C-W OSCILLATOR SWITCHING AND A-V-C TIME CONSTANT

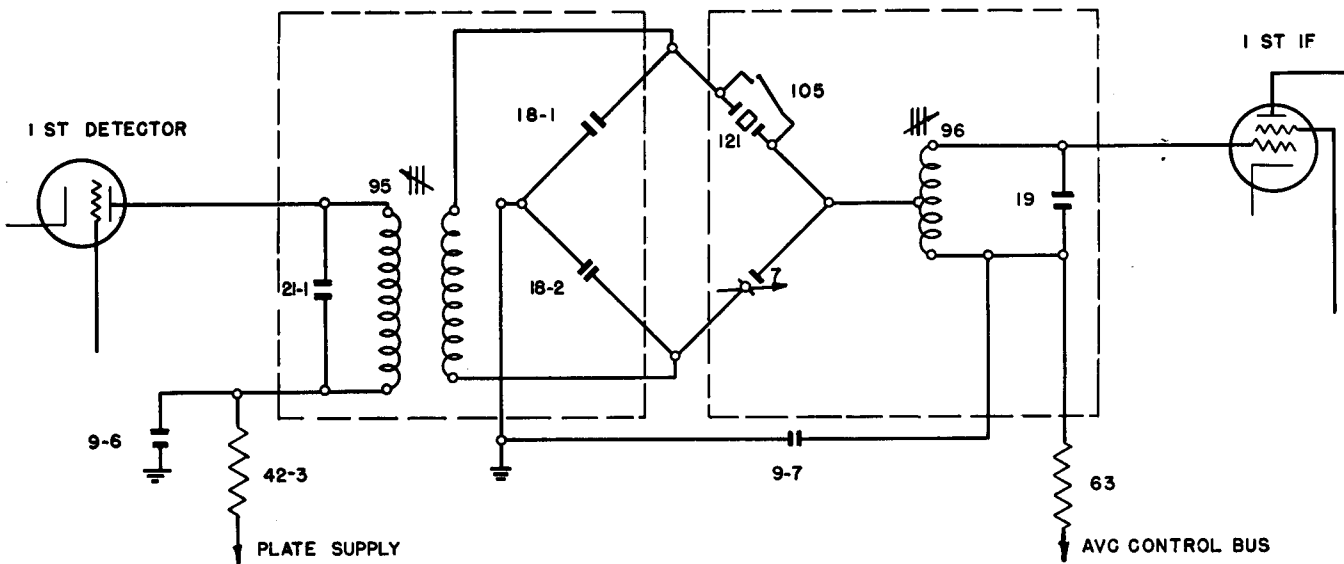

FIGURE 16—CRYSTAL FILTER CIRCUIT

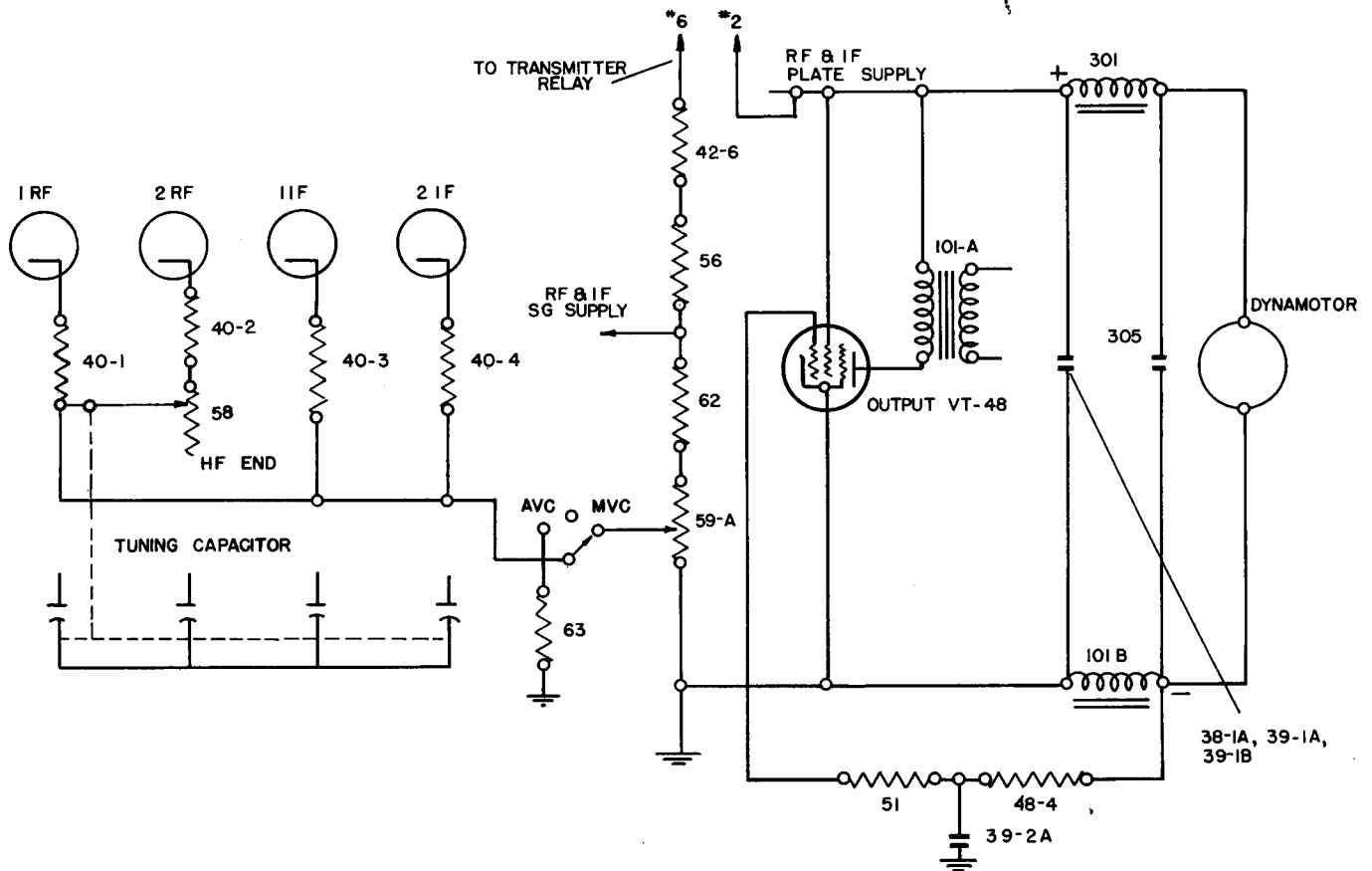

FIGURE 17—LOAD COMPENSATOR, BLEEDER CIRCUIT AND NOISE COMPENSATOR

in or out of the circuit by CRYSTAL OUT-IN switch 105 actuated from the front panel. The filter band width is adjustable by means of balancing capacitor 7. As delivered by the manufacturer, the band width is set at approximately 2,000 cycles. For adjustment see Paragraph 35c (10).

25. SECOND DETECTOR AND AUTOMATIC VOLUME CONTROL

Tube VT-93 also functions as the second detector and automatic volume control. A relatively high level signal is supplied by the third i-f amplifier to the diodes of this tube. One diode functions as the signal detector while the other diode is capacity coupled and provides high level, delayed a-v-c control bias.

26. OUTPUT

a. Description

The high level signal diode supplies audio output for driving output tube, VT-148,

without additional audio amplification. The design choice of three i-f amplifier stages and high level detection results in a number of operating advantages. The high level detection is relatively free from distortion due to avoiding the characteristic curvature at the lower end of the diode curve. The direct drive of the output tube from the diode detector simplifies the dynamotor ripple filtering and eliminates possible microphonics resulting from high audio amplification. The high diode level further provides relatively high bias voltage insuring an unusually flat automatic volume control characteristic with the desired time delay. The dual volume control comprises potentiometers 59-A and 59-B. The latter, 59-B, functions only with switch 107 in the a-v-c position and in this condition it permits the desired adjustment of the audio level to the output tube and load. For manual volume control with switch 107 in the m-v-c position, the potentiometer 59-A becomes the active con-

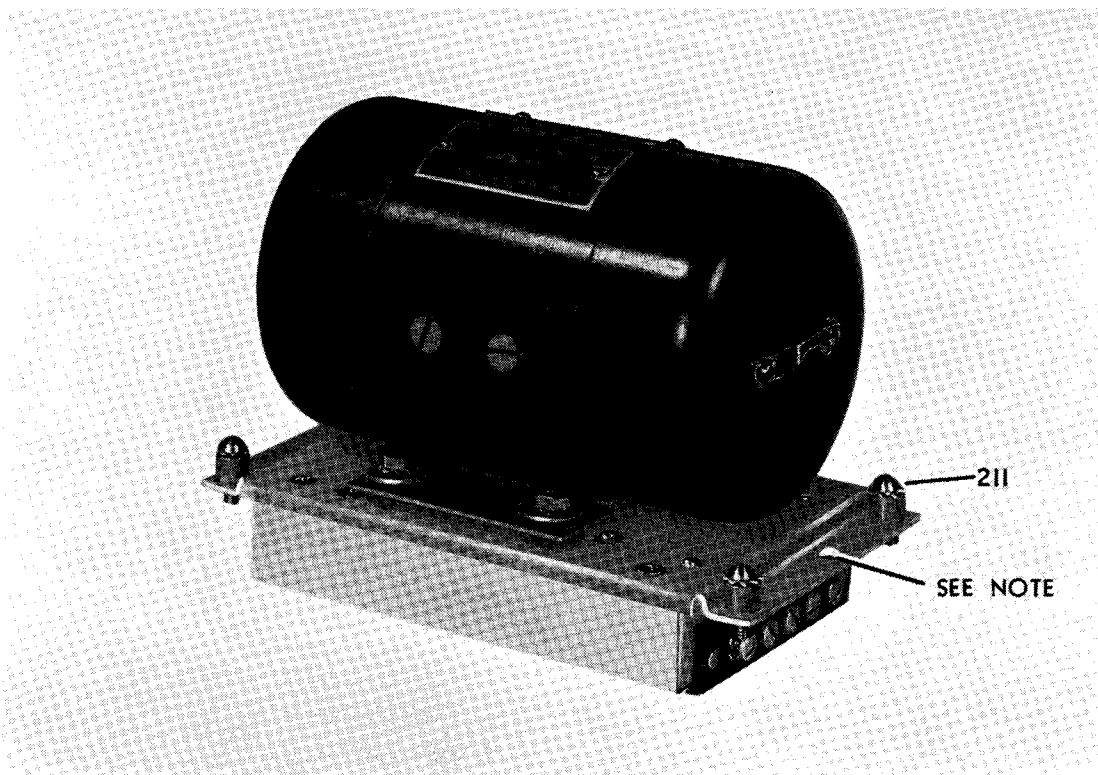

FIGURE 18—DYNAMOTOR

trol operating on the cathode bias of the r-f and 1st and 2nd i-f amplifier tubes. These potentiometers have two linear resistance tapers providing a smooth variation of sensitivity. Automatic load compensation is obtained by the method of biasing the output tube. Here, the grid bias is obtained from the resistance drop across the dynamotor filter reactor, thus, any tendency towards a decreasing load on the dynamotor results in a slight decrease in the bias of the output tube with a compensating increase in the load current. (See Figure 17) Tube VT-48 provides a considerable margin of power capability above that necessary to operate a number of headsets in parallel.

b. Noise Compensator

The characteristic increase of internal receiver noise when tuning from the low to the high frequency end of a band has been corrected in this design by means of variable resistor 58. The function of this potentiometer can be more clearly understood by refer-

ence to Figure 17. Here noise compensator 58 is mechanically connected to the shaft of the ganged tuning capacitor with the electrical connections such as to give minimum resistance at the low frequency end of the band. The cathode return lead of the second r-f amplifier tube connects to noise compensator 58 and hence the gain of this stage is decreased proportionally as the r-f tuned circuit impedance increases when tuning toward the higher frequency end of the frequency band. This arrangement tends to maintain the noise level and receiver sensitivity essentially constant over the tuning ranges.

27. DYNAMOTOR

The dynamotor and associated r-f filter circuits are assembled in one unit. The r-f filters are of

NOTE: Dowel pin on chassis of these radio receivers which fits in hole in dynamotor mounting base, prevents accidental installation of other similar dynamotors with different ratings.

the unbalanced type for use with a primary supply in which the negative side is grounded. This dynamotor supplies all of the high voltage direct current required for the operation of the receiver and, in addition, a maximum of 20 milliamperes for use in operating accessory equipment.

28. CHARACTERISTICS OF TUBES, LAMPS, VOLTAGE REGULATOR AND FUSE

In the following tables are shown the characteristics of the tubes, lamps, voltage regulator and fuse as used in these equipments.

TUBE CHARACTERISTICS

Tube	Heater		Screen Volts	Plate Volts	Grid Volts	Plate Screen			Plate Resistance Ohms	Transcon- ductance Micromhos
	Volts	Amps				Ma	Ma	Mu		
VT-86	6.3	0.3	100	250	-3	7.0	1.7	1,160	800,000	1,450
VT-91	6.3	0.3	100	250	-3	2.0	0.5	1,150	1,500,000	1,225
VT-70	6.3	0.3	100	250	-3	6.5	1.5	900	850,000	1,100
		Tri	...	100	-3	3.5	...	8	16,000	500
VT-93	6.3	0.3	125	250	-3	10	2.3	800	600,000	1,325
VT-65	6.3	0.3	...	250	-8	8	...	20	10,000	2,000
VT-48	6.3	0.4	250	250	-18	32	5.5	150	68,000	2,200

Dial Lamps				Voltage Regulator (RCA-991)	
Lamp	LM-27	6.3 volts	0.25 amp	Starting Supply Voltage	87 volts min.
		Fuse		Operating Voltage	60 volts
Fuse	FU-35		5 amp	Operating Current	0.5 to 2 milliamperes

(blank)

26

SECTION IV

MAINTENANCE

NOTE—No attempt at either mechanical or electrical servicing of these receivers should be made except at Signal Corps Repair Shops and Signal Corps Radio Sections (or Signal Sections) at Air Depots, unless suitable shop and testing facilities are available and authority to repair has been granted by the Corps Area Signal Officer. A standard signal generator, a phantom antenna, Test Set I-56-C, and other like equipment should be used for alignment purposes and the instructions in this book carefully followed.

29. INSPECTION

- a. *Daily*—Turn on receiver. Check dial lamps. Check for operation on all bands with c-w oscillator ON. This test can best be made by observing noise level with volume control at maximum.
- b. *After 20 hours operation*—Repeat above with additional check of antenna, ground and cable connections for effects of vibration.
- c. *After 40 hours operation*—Repeat above with additional check of all vacuum tubes, regulator tube and dial lamps. Inspect receiver for loose grid clips, tube shield, etc. Inspect all tubes with combination Tester of Test Set I-56-C.
- d. *Each 6 months*—Repeat above with additional cleaning and lubrication of dynamotor as described in paragraph 30.
- e. *1 Year*—Repeat above with inspection and replacement of dynamotor brushes, if necessary. Lubricate dial and tuning condenser drive mechanism. Check dynamotor and tube socket voltages as described in paragraphs 35c (1) and 35c (3).

30. CARE AND SERVICING OF DYNAMOTOR

- a. The dynamotor and filter assembly is removable from the receiver chassis without disturbing other parts, provided the procedure outlined below is followed:

Loosen the two thumb screws on the receiver panel, and draw the chassis from the cabinet.

Lay the chassis with top upwards on a smooth, flat surface with the rear toward the operator.

Loosen the five connector screws on the dynamotor terminal strip and withdraw the spade terminals from beneath them. Loosen the four captive screws 211, Figure 18, which hold the dynamotor unit to the chassis.

Remove the dynamotor and filter assembly from the receiver by grasping the dynamotor and lifting vertically.

The filter portion of the dynamotor unit is made accessible by the removal of the cover at the bottom. See Figure 19.

This dynamotor requires lubricating after 1000 hours or approximately 6 months of ordinary service and should be lubricated with none other than Air Corps Grade 375 grease. Directions for lubrication are stamped on the inside of the end-bell dust covers. Access to the bearings of the dynamotor is obtained by first removing the dust covers after cutting the safety wires and removing the retaining screws, then unscrewing the bearing end plates. Do not PACK the lubricant in these bearings.

- b. When necessary to replace the ball bearings or turn down the commutators, first remove the brushes from their cartridges. Remove the nuts from the tie rods which hold the bearing end-bells and pull the end-bells away from the field coil assembly. The armature can now be taken out. Examine the brushes to see that they have worn properly and are free from hard spots. Should such spots be apparent (they generally cause grooves in the commutator surface), the brush should be replaced and the commutator smoothed down. The ball bearing retainers and the shaft are machined for very

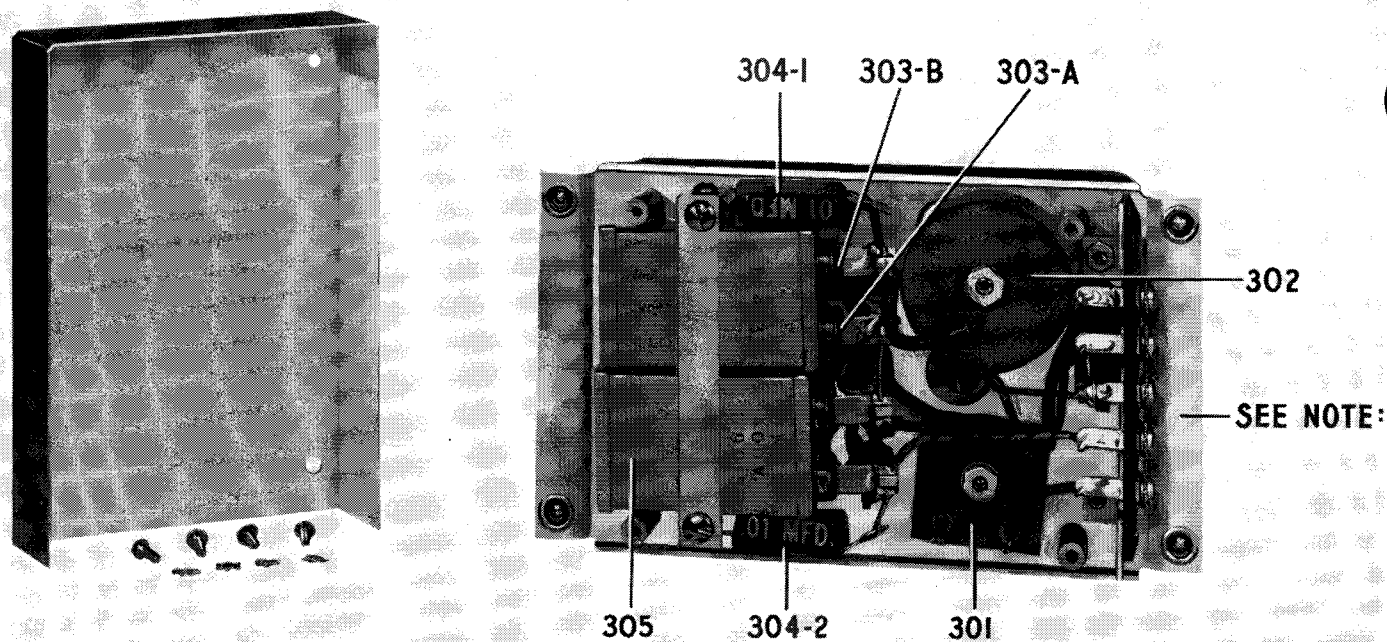

FIGURE 19—BOTTOM VIEW OF DYNAMOTOR SHOWING FILTER OPEN

snug fits, but a slight tapping will loosen them. To remove the bearing retainers from the end-bells use two small screwdrivers as wedges between the outer ball race and the end-bell. If the grease slinger becomes bent during removal, it should be straightened and replaced on the shaft before replacing the bearing.

- c. To smooth down the commutator rotate it in a lathe holding a fine grade of sandpaper not coarser than size 00, lightly against the commutator surface. Do not use emery cloth. All residue of dust, sand and dirt should be wiped away to leave a clean, smooth polished commutator surface. A commutator having a smooth or polished surface should never be sanded or turned down simply because it is discolored. If the commutator is turned down in a lathe, the mica segment separators must be undercut.
- d. Re-assembly of the dynamotor is accomplished in substantially the reverse of the disassembly procedure. In replacing the

brushes, check to see that the + and - markings on the brushes correspond with those on the brush holder supports, and that the marked side of the brush is towards the top of the dynamotor. The commutator must be given a final inspection for free running, cleanliness and absence of grease or oil. The end-bells should be wiped clean and dry before replacing them on the dynamotor.

- e. The nominal rating of the dynamotor is: input, 1.23 amperes at 27.9 volts; output, 70 milliamperes at 220 volts; regulation 12 per cent. Average performance data on dynamotor is as follows: (Dynamotor and filter disconnected from receiver and negative high voltage connection made to case of unit).

NOTE: *Dowel pin on chassis of these radio receivers which fits in hole in dynamotor mounting base, prevents accidental installation of other similar dynamotors with different ratings.*

DYNAMOTOR

Input		Output	
Volts	Amperes	Volts	Milliamperes
24	0.7	215	0.
24	1.1	210	30.
24	1.3	202	60.
28	0.8	258	0.
28	1.1	246	40.
28	1.5	236	75.

31. REMOVAL OF FRONT PANEL

a. For adjustment of dial or mask, or for servicing of certain parts, it may become necessary to remove the panel. The chassis, with panel attached, should be taken completely out of the cabinet and placed for inspection with the panel facing upwards. Unsolder the lead to the antenna binding post and the lead from the chassis to the dial lights. Remove the dial light housing cover, the two thumb screw rods, the handles, and all knobs and retaining nuts of all controls except the DIAL LIGHTS control. The retaining nuts of the TEL. jacks should also be removed. The panel may be lifted off after the removal of the end-plate holding

screws, the chassis holding screws, the dial casting holding screws and a screw which supports the crystal filter assembly to the panel.

b. In replacing the BEAT FREQ. control knob turn the flexible shaft until the set screw in the coupling at the internal end points away from the panel. Now mount the knob so that the arrow points vertically towards the top of the receiver. This knob has two set screws. In replacing the other knobs on the shafts, it will be noted that flats on the shafts provide for proper location. All set screws must be securely tightened, and the set screw on the band switch knob in particular should be given a second

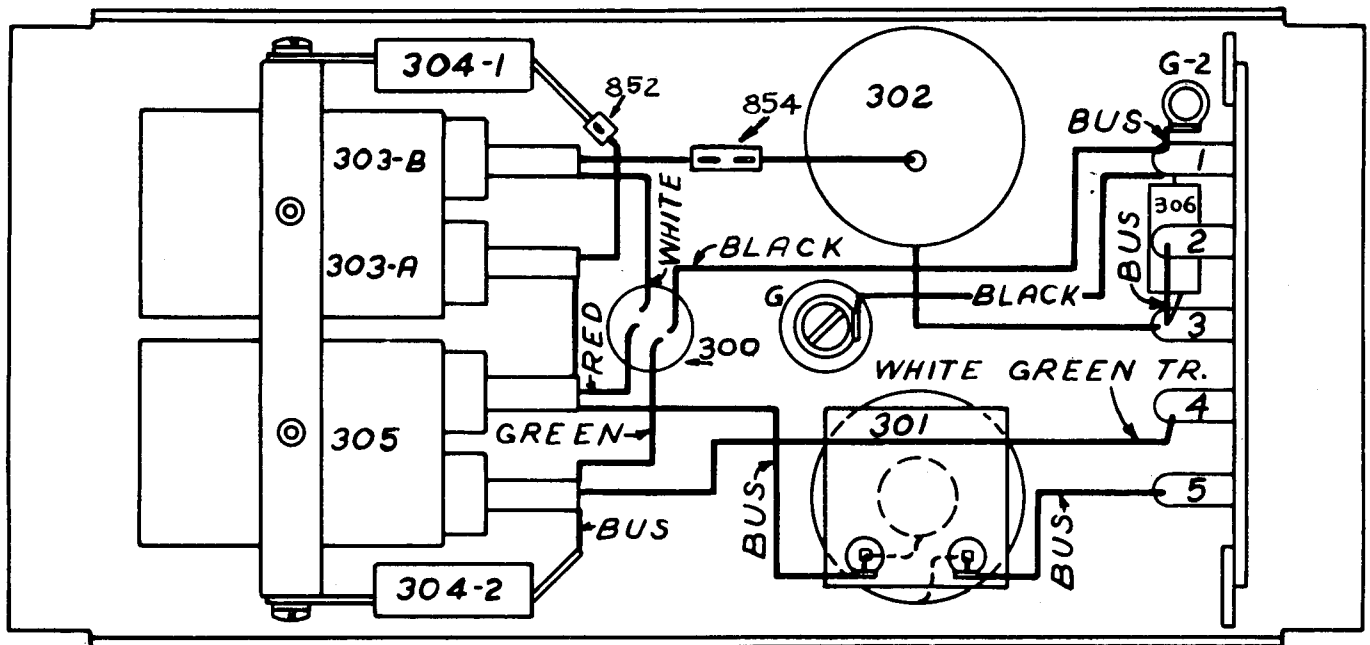

FIGURE 20—DYNAMOTOR FILTER WIRING DIAGRAM

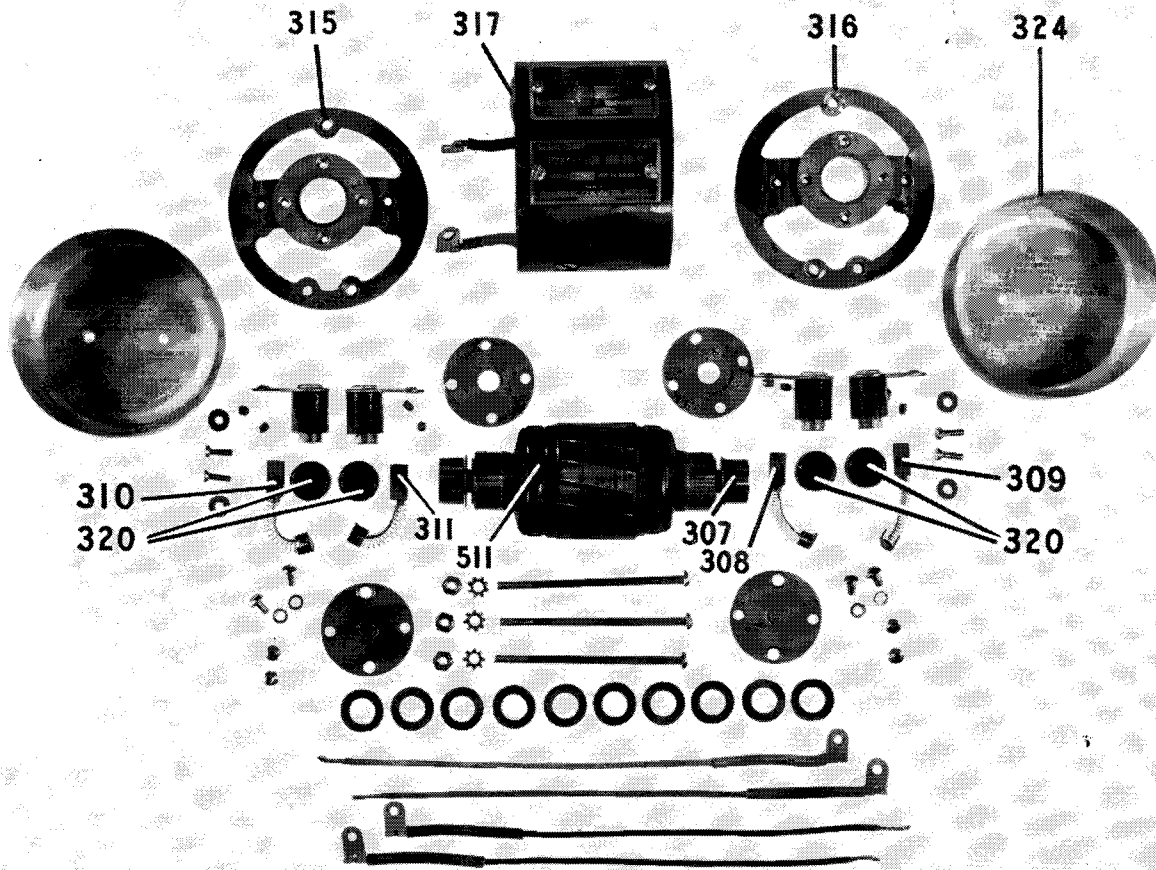

FIGURE 21—DYNAMOTOR DISASSEMBLED

tightening after the shaft has been rotated a few times.

32. DIAL AND MASK ASSEMBLY

a. Attached to the front panel, and to the main frame or chassis casting, is an aluminum casting which is the frame for the switch drive shaft, dial mask and detent, and also for the tuning dial, tuning shaft, reduction gears and stop. All of these parts are assembled, and can be moved, as a unit, which simplifies any service operations which might be required.

b. The switch drive shaft passes through a hole in an adjustable plate located in the dial lamp housing and through a clearance hole in the panel. The hole in the adjustable

plate is purposely given a larger clearance than bearing requirements would dictate, since its use is to support the shaft against forces which might spring it or damage the internal bearing. The shaft extends through a long bushing pressed in the dial housing. At the inside end of the shaft, the detent (star wheel) and the driving portion of the coupling member are pinned in place by means of taper pins. The dial assembly runs on the outside surface of the long bushing referred to above. Just inside the panel the shaft has attached to it by taper pin, the hub of the mask.

c. On the back of the dial frame casting is a stop arm, which engages a pin in the detent so as to limit its rotation to 6 positions which are spaced 60 degrees apart. There is at-

tached the assembly of pivot pins, arms with rollers, and spring which positions the detent. This assembly is locked with two dowel pins after the correct location is made.

d. On the front (panel end) of the bushing through which the switch shaft passes, there is a narrow shoulder which supports the lower end of the dial index plate. This index plate is attached to the casting at its upper end with means for removing any slack and keeping it straight and taut. The inner end of the mask hub and the outer end of the dial hub turn and are held against opposite sides of the index plate.

e. The dial is attached to a flange on a hub which runs on the outside surface of the bushing through which the switch drive shaft passes. This hub also carries a large gear which is driven by a pinion combined with a split idler gear. This split idler gear and pinion has adjustment in the clearance holes for the mounting screws to enable the backlash in the mesh of the pinion with the large dial gear to be reduced to the smallest practicable amount when assembling.

f. The tuning shaft has, in addition to the pinion referred to above, a stop, and a worm which meshes with a split worm gear on a cross shaft at the back of the frame. Both this cross shaft and the tuning shaft run in bearings which are integral in the casting. Both shafts have spring thrust washers to remove end play. The cross shaft carries a pinion which is meshed with a split gear on the tuning capacitor shaft at assembly. The degree of mesh of this pinion and gear is adjustable by moving the tuning capacitor toward or away from the panel after it is placed in position and before the holding screws are finally tightened.

g. The overall gear ratio between the tuning shaft and the capacitor shaft is 200 to 1. Since the design of the tuning capacitor permits but a small amount of rotation at either end of its travel beyond the 180 degrees required to give it complete range in electrical capacity, means are provided to stop the tuning shaft at either end of a total of approximately 100 revolutions. This is accom-

plished by a cam on the outer edge of the tuning dial which operates an arm pivoted on a pin on the frame casting. One end of this arm has a roller which runs on the outer edge of the dial. The roller is held in contact with the dial by a spring. The edge of the dial is cut away in such a manner that when the point corresponding to either end of the tuning capacitor travel is reached, the roller, and therefore the end of the arm, can move toward the center of the dial, being forced in that direction by the spring. Thus the opposite end of the stop arm is moved so that the hook at the end of the arm engages the rotating stop on the tuning shaft and the shaft is thereby prevented from further turning. When the direction of rotation of the tuning shaft is reversed, the roller and arm are pushed outward against the spring by the cam edge of the dial, and the stop disengages.

h. Since a definite relation must be set and maintained between the dial position and the angular position of the rotor of tuning capacitor, adjustment is provided at the pinion on the cross shaft at the rear of the frame. (This is the shaft which also carries the worm gear). This pinion is held in place by two set screws which bear in a groove on the shaft. By loosening these two set screws, either the dial or the tuning capacitor can be rotated while the other part remains fixed. The correct relation between these is such that the tuning capacitor rotor plates are fully meshed with the stator plates (maximum capacity) when the dial is set with the isolated index mark at the low frequency end of the 13.5 -- 18.0 MC. band in line with the index.

33. REMOVAL AND REPLACEMENT OF DIAL MECHANISM

a. In the event that the dial mechanism is to be removed from the chassis for any servicing operations, it is necessary first to remove the front panel in accordance with instructions given earlier in this book (Paragraph 31). The frame of the mechanism is attached to the chassis by the bracket holding the fuse, and by two slotted hexagonal head screws through the flange on the under side

of the chassis. Note that one of these screws is beneath the removable shield which covers the terminals of the first i-f transformer. When these screws are removed, the complete unit can be removed. The center disc of the flexible coupling is loose and will drop out of engagement.

- b. To remove the index and dial, the taper pin holding the mask hub to the switch drive shaft must be removed. It is necessary to support the shaft when driving out this pin so that excess stress will not be placed on the center bushing. After the removal of the mask and the index, the dial and its gear are free to slide off the bushing. In replacing these parts, the thrust washer behind the dial hub must be turned in the position to give maximum thrust, which is with the convex side outward.
- c. If the dial is removed and replaced, it is possible that in meshing the dial gear with the idler gear, the stop relationship may not be correct, in which case it may be necessary to change the meshing a tooth at a time in order to correct the error. The stop relationship must be such that the roller arm hook and the tuning shaft stop arm engage fully at the end of the last revolution. On the previous revolution, the arm must not start to move until after the rotating arm has passed under the roller arm hook. This adjustment can only be made by trial and inspection, but it can be secured in one or two trials. Substitution of a different stop arm may also require re-adjustment but in this case the adjustment should be made by lengthening or shortening the roller end of the arm. This is done by loosening the two nuts on the arm, after which the arm can be adjusted by the slotted holes provided.
- d. When the dial mechanism is replaced, the flexible coupling must be properly positioned so that the position of the mask corresponds to the switch position. Otherwise the band switches will not operate properly. The correct relative positions are obtained when the mask is set to band 200-500 kc and the set screw locking the flat switch shaft to the large bevel gear hub is 15 degrees back (away from panel) from vertical.
- e. If any of the gear trains including split

gears have been unmeshed in disassembly, the split gears must be reset to put tension on the loose section when they are again meshed. Normally a displacement of one tooth between the two sections is sufficient. Trial will show whether this will remove the backlash.

- f. When the dial mechanism is re-assembled to the chassis, the relation between the dial and the tuning capacitor must be carefully adjusted in order to maintain the calibration and prevent over-running the capacitor (Refer to Paragraph 32h). This is done by loosening the two set screws in the pinion on the cross shaft on the back of the dial assembly. Before putting the mechanism in place, this pinion can be moved along the shaft toward the worm gear so as to clear the capacitor split gear. This facilitates assembly, since the gears can be meshed after the dial mechanism is bolted in place, making it easier to get the tension on the split gear in the capacitor assembly.

34. REMOVAL OF ANTENNA, R-F, DETECTOR AND OSCILLATOR UNITS

In many cases servicing of these units will require only the removal of the top or bottom cover of a particular unit; however, any unit may be removed and replaced independently as follows:

- a. Unsolder the lead to the main tuning capacitor at the capacitor by first removing the capacitor shield. Unsolder all other leads at the unit.
- b. Disconnect the band switch drive shaft and withdraw it from the antenna unit end.
- c. In case of antenna unit, disconnect the antenna alignment control shaft.
- d. Remove screws holding unit to the tie strips at the bottom.
- e. Remove screws holding the unit to the chassis.
- f. Lift the unit from the receiver, taking care that it comes out freely.

When replacing a unit, reverse the above procedure; however, do not tighten the chassis-holding screws tightly until the drive shaft has been replaced and the band change switch knob has been rotated a number of times. This will insure the self-alignment of the unit and the proper action of the detent.

35. TROUBLE LOCATION AND REMEDY

a. General

The normal sensitivity (number of microvolts input to produce 10 milliwatts output into a 4,000 ohm resistance load) of the receiver is better than 3 microvolts when measured under the following conditions:

AVC-OFF-MVC switch at MVC; 28 volts input; c-w oscillator ON; crystal filter OUT; output load 4,000 ohms non-inductive resistance; pure c-w input from signal generator applied between antenna ground terminals through a 100 mmf dummy antenna; volume control set to produce 0.3 milliwatts noise output.

This sensitivity will, of course, be subject to variation with time due to tube aging, etc. Therefore, it is recommended that no attempt be made to retrim or realign the equipment unless the sensitivity is found to be worse than 20* microvolts with new, average tubes. This receiving equipment has been carefully adjusted and aligned by the manufacturer before shipment and should maintain these adjustments over reasonably long periods of time. Major adjustments and repair should be made only in an authorized repair shop equipped with the necessary servicing tools and equipment. All others must refrain from changing any of the ad-

*Input signal at terminals of antenna required to obtain 10 milliwatt output over internal noise.

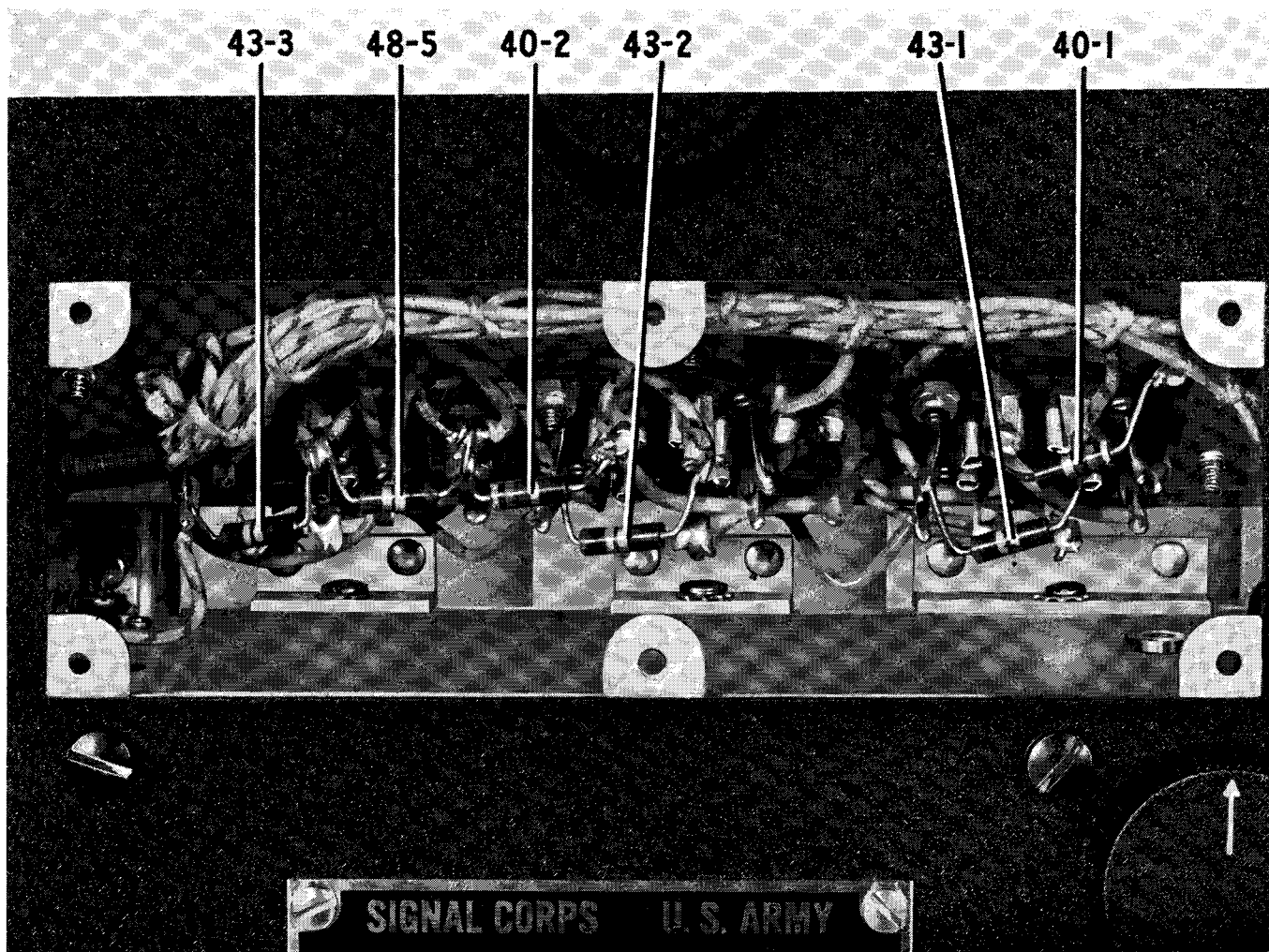

FIGURE 22—DETAIL OF TUBE SHELF ARRANGEMENT LOOKING THROUGH PANEL OPENING, COVER REMOVED

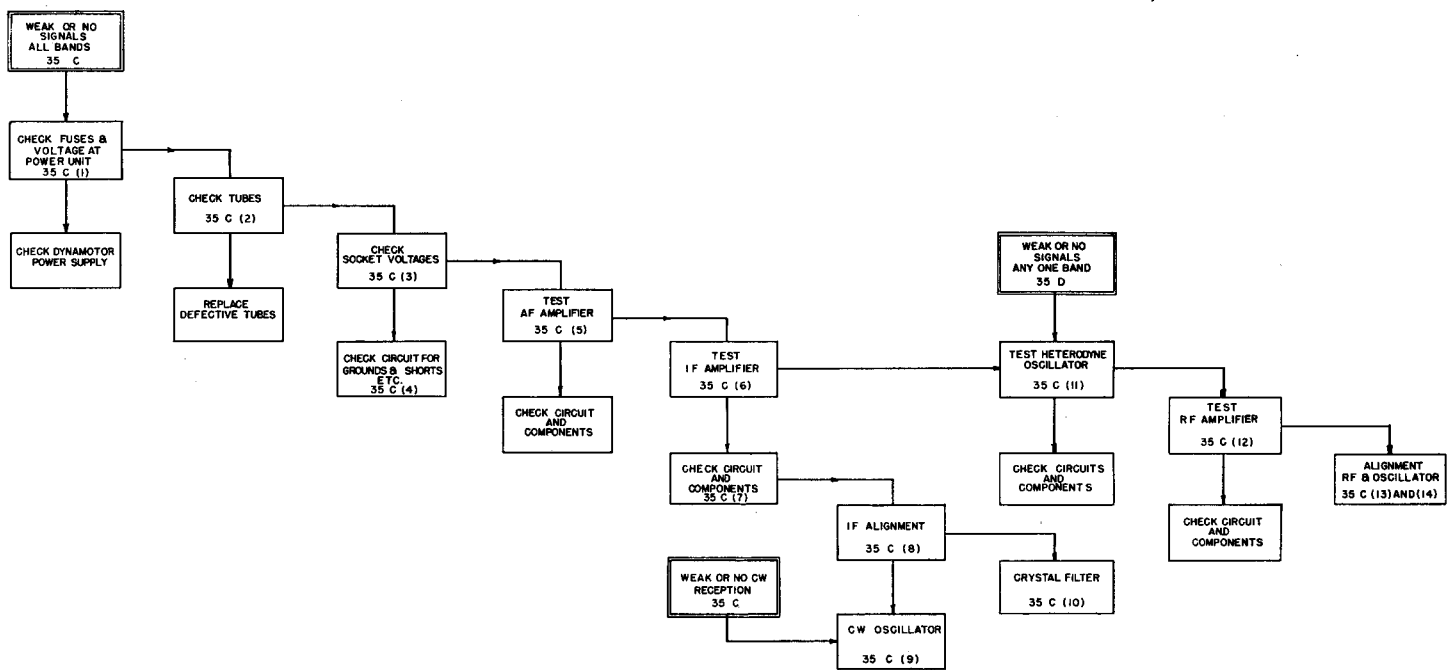

FIGURE 23—TROUBLE LOCATION AND CORRECTION CHART
(Numerals refer to pertinent paragraphs)

adjustments of the radio frequency circuits. The difficulties usually experienced are the result of external deteriorating influences, such as worn-out vacuum tubes, improper operating voltage, blown fuse, external noises, etc. However, in order to permit the

servicing of this equipment, the testing procedure shown should be followed in determining the source of trouble. This has been divided into the following major divisions, with respect to the nature of the troubles being experienced:

EQUIPMENT REQUIRED—see Paragraph 35 b

Weak or No signals on all bands	Modulated reception	See Paragraph 35 c
Weak or No signals on any one band	Modulated reception	See Paragraph 35 d
Weak or No signals on all bands	C-W reception (modulated reception normal)	See Paragraph 35 e

Figure 23 graphically outlines the procedure for trouble location, the numbers in each block referring to the paragraph numbering in the following discussion:

b. Equipment Required

Few instruments other than those found in a standard set analyzer (Test Set I-56-C) are required in locating the most probable troubles in this receiver. The individual instruments required are as follows:

- (1) A modulated test oscillator (standard signal generator) with a frequency range from 200 to 18,000 kc with provision for calibration accuracy better than 0.1% at aligning frequencies.
- (2) *Voltmeter—1000 ohms per volt, ranges: 0-10; 0-100; 0-250 volts.
- (3) *Continuity tester.
- (4) *Output meter rectifier type, 0-15 volt, 4,000 ohms.

*Part of Test Set I-56-C.

- (5) Microameter, 0-200.
- (6) Audio frequency oscillator.
- (7) Pair of telephone receivers.
- (8) Adapter FT-211 which consists of an 8-prong octal plug and an 8-prong octal socket connected together by a short length of 8-conductor cable, to permit use of Test Set I-56-C analyzer on the r-f tubes on the tube shelf.

c. Weak or No Signals on All Bands, Modulated Reception

(1) Check of Dynamotor Voltages

When all signals on all bands are weak, or no signals are heard even when known to be present, the procedure follows that shown in the chart. The voltages checked

at the dynamotor terminal board should closely approximate the values shown in Figure 24 for this equipment. Conditions of measurements are as follows: Input voltage 28 v for these receivers; Crystal OUT; MVC; Volume Max.; C-W Osc. OFF; Load resistance 4000 ohms.

If these voltage readings do not approximate the values shown, *check* the fuse, dynamotor and filter circuits, wiring and components.

(2) Tube Check

If the voltages at the dynamotor terminal board approximate the values given, proceed to check all tubes for emission and characteristics or replace all tubes with those of known average characteristics.

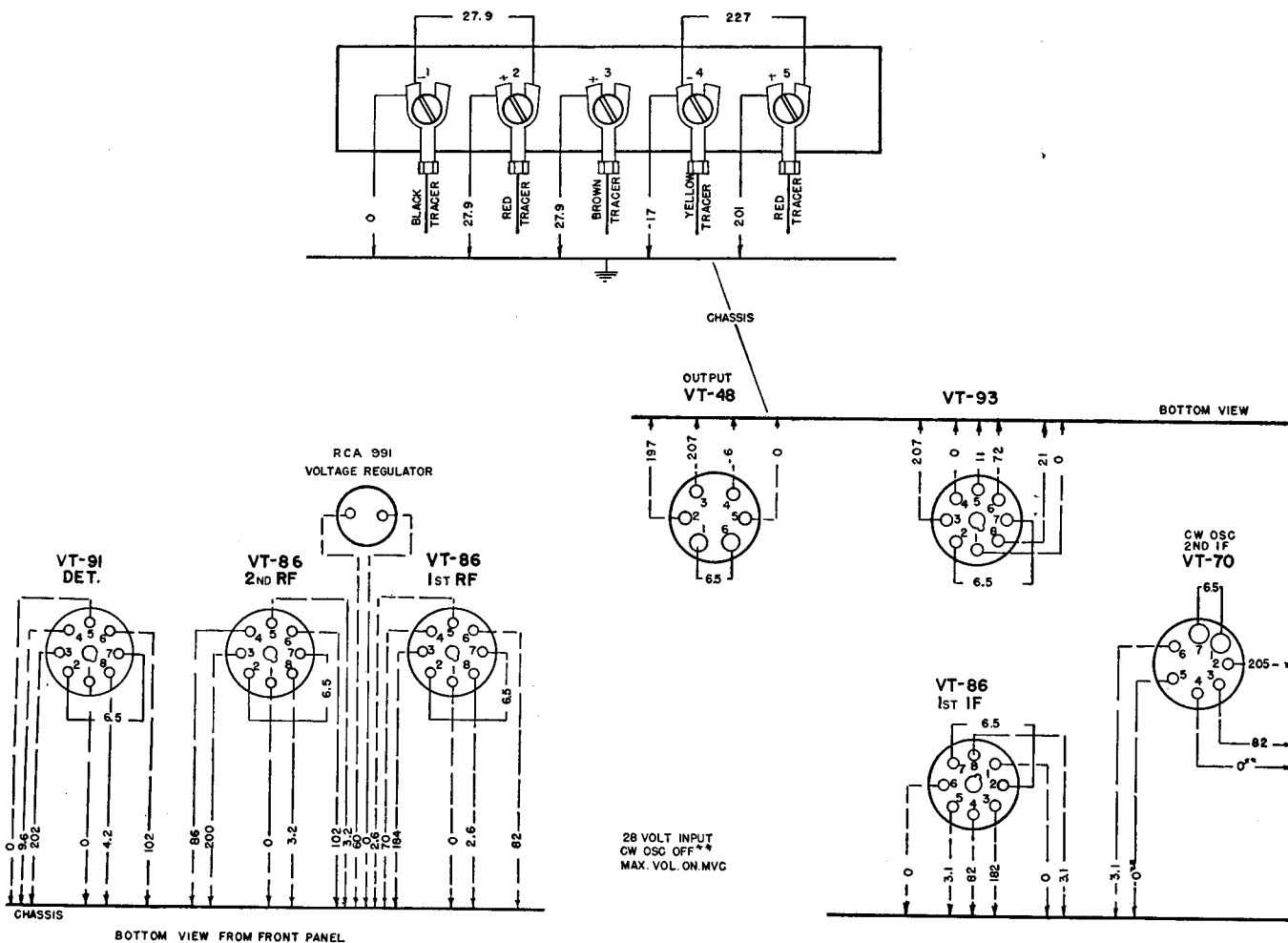

FIGURE 24—CHART OF SOCKET AND DYNAMOTOR VOLTAGES

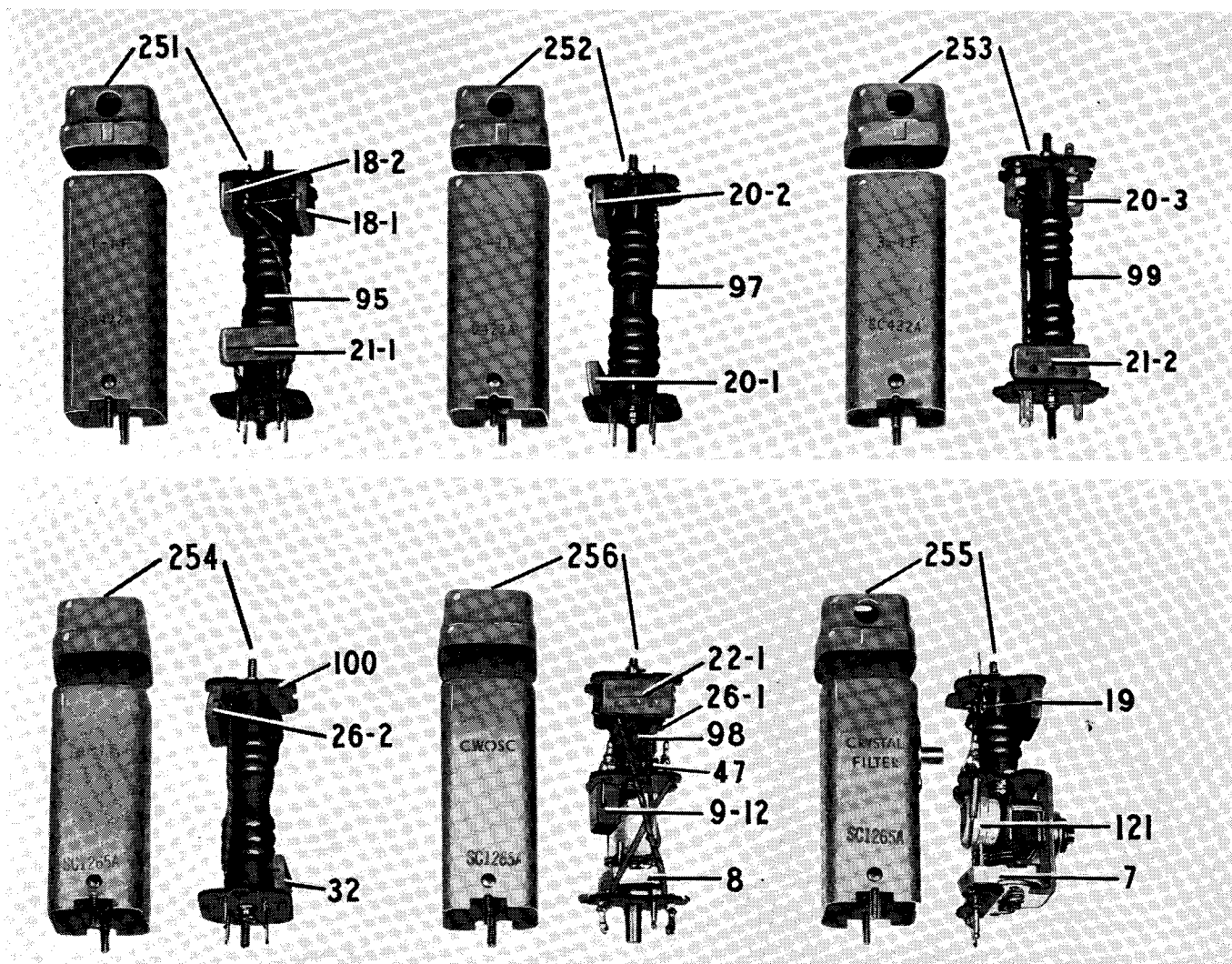

FIGURE 25—INTERMEDIATE FREQUENCY C-W OSCILLATOR COIL AND CRYSTAL OF FILTER ASSEMBLY

(3) Check of Socket Voltages

If tubes check satisfactorily, or if after replacing with tubes known to be good, the sensitivity is still low, proceed to check all tube socket voltages as outlined under Paragraph 35f with Test Set I-56-C. The average socket voltages are given in Figure 24.

(4) Check of Circuit Wiring and Components

If the tube socket voltages do not approximate the values shown in Figure 24 the associated circuits and components should

be checked for grounds, shorts and similar defects.

(5) Test of Audio-Frequency Amplifier

Having checked all socket voltages and found the values to be correct, proceed to the test of the audio frequency amplifier. This can be checked by capacitively coupling a 400-cycle voltage of approximately 2 volts rms. Between the detector diode socket prong No. 4 and ground, through a 0.5 mfd capacitor. As an alternative a modulated 915 kc signal of 2 volts may be coupled to this point and ground. Proper functioning of the audio amplifier will be

indicated by an output well over 10 milliwatts for the 2-volt audio input or approximately 1 milliwatt output for 915 kc input. Circuits, wiring and components should be checked if this order of response is not obtained.

(6) Test of Intermediate-Frequency Amplifier

Following a satisfactory test of the audio amplifier, check the intermediate frequency amplifier by capacitively coupling the modulated test oscillator from the grid cap of the first detector tube to ground, through a 0.1 mfd capacitor, the frequency being adjusted to 915 kc. A rough check of the proper functioning of the i-f amplifier is indicated by a comfortable headphone output level with low input from the test oscillator. (Approximately 25 microvolts input for 10 milliwatts output).

(7) I-F Amplifier Circuit Check

If the i-f amplifier does not respond as above or lacks sensitivity, a progressive check, stage by stage, should be made. The test oscillator 915 kc modulated input, is connected through a 0.1 mfd capacitor to the second detector diode socket prong and to ground. A signal response indicates proper functioning. Coupling the test oscillator to the grid of the third i-f should indicate a decided gain in sensitivity. Proceeding similarly towards the first detector, each stage should show a decided gain, and a faulty stage can be circuit checked for grounds, shorts, or defective components.

(8) Alignment of I-F Amplifier

When all stages have been tested, the i-f amplifier alignment is checked by capacitively coupling a low level input signal of 915 kc to the first detector grid and adjusting the i-f tuning cores of both primary and secondary windings of the first, second and third i-f transformers and the tuned circuit of the crystal filter assembly for maximum output. The fourth i-f transformer is slightly over-coupled with

the resultant double response peaks symmetrically located approximately 5 kilocycles each side of the 915 kc i-f alignment frequency. In general, it will not be necessary to realign this transformer because of its broad characteristic. However, if realignment becomes necessary, the following procedure should be followed.

Connect the modulated test oscillator through a 0.1 mfd capacitor to the grid of Tube VT-93 (third i-f amplifier tube) and to ground. Set the input frequency at 910 kc and adjust alternately first the primary tuning core, then the secondary tuning core of the fourth i-f transformer until maximum output is obtained when both cores are turned in a right-hand screw direction. The modulated test oscillator should then be turned slowly through the 915 kc setting and to approximately 920 kc where a second response peak of approximately equal amplitude as that at 910 kc should be obtained. This indicates correct alignment. Slight supplementary adjustments of the primary and secondary tuning cores may be necessary to secure a symmetrical double peak response with the slight hollow between response peaks located at the 915 kc alignment frequency. If a sweep frequency modulated test oscillator is available, this fourth i-f transformer can be conveniently aligned by visual observation on a cathode ray oscilloscope. In this case, the tuning core adjustments are made to obtain a double peak response pattern centered at 915 kc.

(9) Check and Alignment of C-W Oscillator

The c-w oscillator is checked and adjusted by coupling the 915 kc input (modulation off) to the grid of the first detector tube and then switching the c-w oscillator ON. With the beat frequency control set at mid-position, oscillator inductance tuning core 98 is adjusted for zero beat. If no c-w beat can be heard, the c-w oscillator circuit should be checked for grounds, shorts, or defective components. With the c-w oscillator ON the screen voltage at the first and second i-f sockets drops to approximately 45 volts (measured to ground).

(10) Test and Adjustment of Crystal Band-Pass Filter

Normally the crystal band-pass filter is adjusted at the factory for a bandwidth of 1500 to 2000 cycles at 20 db down from resonance. This filter can be tested by applying an unmodulated signal of approximately 915 kc, connected through a 0.1 mfd capacitor to the grid of the first detector tube and ground. With the crystal filter switch in, and a 200-microampere meter connected in the lead from the volume control 59-B to the cathode of the third i-f amplifier Tube VT-93 (available at the bottom terminal of the rear volume control), the frequency of the test oscillator should be slowly varied until the response peak of the crystal filter is located. The signal input voltage or the volume control (MVC) should then be adjusted to give a reading of approximately 70 microamperes on the response peak. Switching the crystal filter OUT should not produce a reading of more than 110 microamperes. This test indicates the correct functioning of this filter. The c-w oscillator should be off during this test. To adjust the band width of the crystal filter, a signal generator or microvolter having an expanded tuning scale in the vicinity of 915 kc and having also an attenuator with a multiplier of 10 times (20 db) is required. The following procedure is recommended: With the signal input tuned to the crystal filter response peak (CRYSTAL IN) and an output reading of 100 microamperes, the attenuator is set to multiply the input voltage by 10 times and the signal generator detuned on each side of resonance, noting the frequencies of the points where a reading of 100 microamperes is again obtained. From the difference of these frequency readings, the crystal filter band width can be determined. The band width can be adjusted by changing the capacity setting of balancing condenser 7. For each setting of this condenser, the bandwidth at 10 times input should be checked as described above. In general the minimum bandwidth is obtained with the balancing condenser at approximately mid-capacity (adjustment slot perpendicular to front panel) with the

band width increasing for condenser settings near maximum or minimum capacity (adjustment slot parallel to front panel). After concluding the above described tests, remove the microammeter and restore the circuit to normal.

(11) Check of Heterodyne Oscillator

Having checked the functioning of the i-f and audio amplifiers, if signals are not heard on any band, the heterodyne oscillator should be checked for oscillation. This can be done by observing the cathode voltages at the socket of the first detector, Tube VT-91, when grounding the stator of the oscillator section (1-D) of the tuning capacitor. If no change in voltage is noted with this test, the oscillator circuit should be checked for grounds, shorts or defective components.

(12) Test of the R-F Amplifier

Having completed the test and alignment of the audio amplifier, i-f amplifier and heterodyne oscillator, the r-f amplifier is tested as follows: With the band switch set on the band lacking sensitivity, a modulated signal from the test oscillator is capacitively coupled through a 100 mmf dummy antenna to the antenna post and to ground. This input signal frequency should be set quite accurately to the alignment frequency shown in the "Table of Alignment Data" for the band under test. With the tuning control set for the approximate alignment frequency, tune slowly around this point until the maximum response with the least signal input is obtained. Capacitive coupling of the test oscillator to the grid of the first r-f and second r-f tubes should show a progressive decrease in output indicating the proper functioning of the particular r-f stage or circuits preceding. If a decrease in response is noted when the signal input is capacitively coupled progressively from the grid of the first detector to the second and first r-f grid caps and finally to the antenna post (with the 100 mmf dummy antenna capacitor), the stage which indicates a decrease in response should be checked for circuit, ground, shorts or defective components.

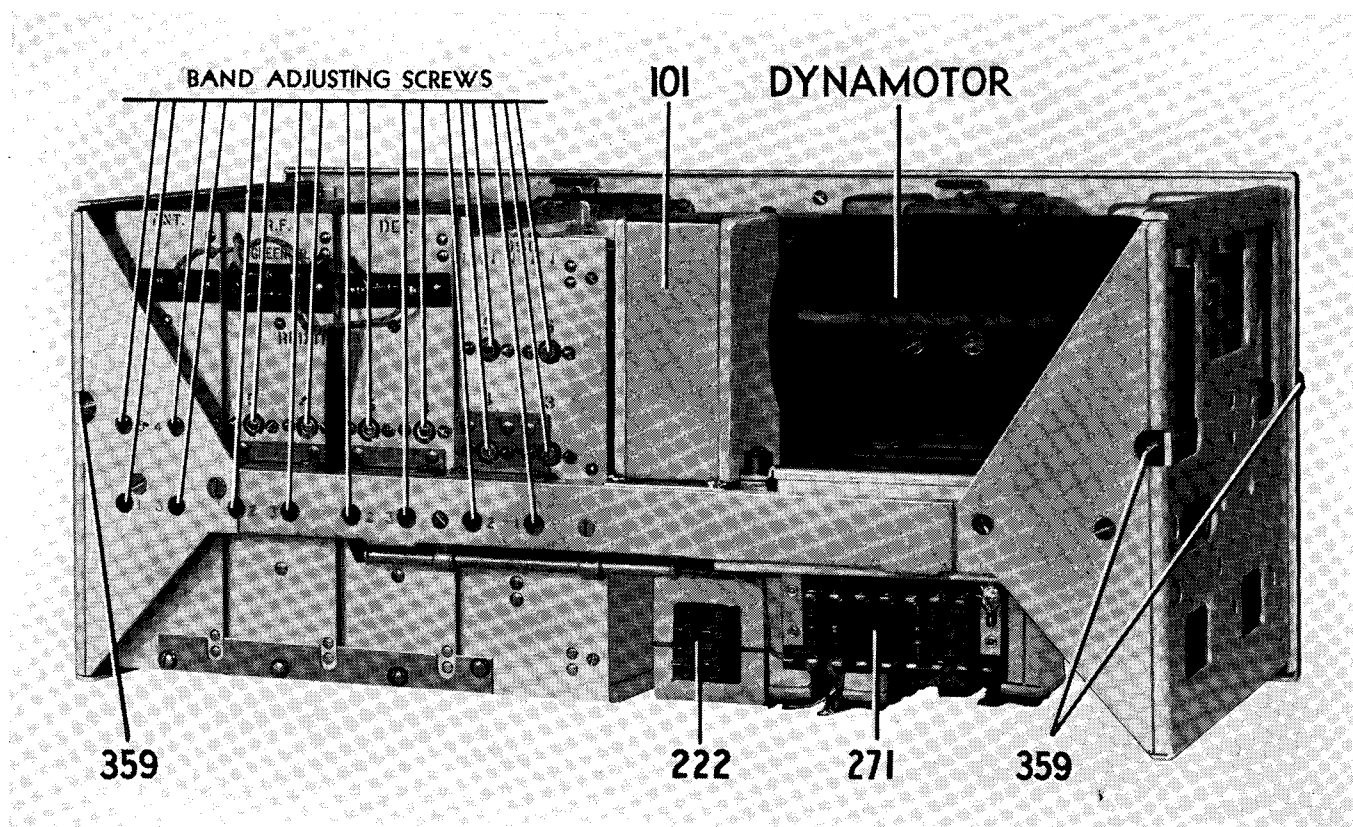

FIGURE 26—REAR VIEW OF CHASSIS

(13) Alignment of R-F Amplifier

NOTE: For a general alignment start with the 200-500 kc Band No. 1.

In the r-f alignment for any particular band, the tuning control is adjusted for the alignment frequency (Table of Alignment Data) and the modulated test signal at this alignment frequency is coupled from the test oscillator to the antenna post through the 100 mmf dummy antenna. The three r-f trimmers (ANT., R-F, and DET.) for this band, are then adjusted for maximum output. A similar procedure is followed in the alignment of each band.

(14) Alignment of Heterodyne Oscillator

NOTE: For a general alignment start with the 200-500 kc Band No. 1.

The alignment of the Heterodyne Oscillator is necessary only when the tuning dial frequency calibration is in error by more than 0.5 per cent. To align the

oscillator follow the same general procedure as was followed for the alignment of the r-f amplifier. With the *band switch* on band No. 1 (200-500 kc) and the *tuning control* set to the alignment frequency, couple the output of the modulated test oscillator (set at the alignment frequency) to the antenna post through the 100 mmf dummy antenna. The oscillator trimmer for this band is adjusted for maximum audio output. A similar procedure is followed in the alignment of each band.

d. Weak or No Signals On Any One Band, Modulated Reception

The condition of satisfactory reception on several bands and weak or no signals on one or more bands, indicates the correct functioning of the i-f and a-f amplifiers and requires checking only the r-f amplifier and heterodyne oscillator for the defective band or bands. The procedure outlined in Paragraphs 35c (11) to 35c (14) should be followed for the defective band or bands.

Table of Alignment Data

Band No.	Freq. Range MC	Alignment Frequency MC	Trimmers*			
			Ant.	R. F.	1 Det.	Osc.
1	200-500kc	480 kc	65	37-1	37-2	6-1
2	1.5-3.5	3.3 mc	2**	5-3	5-5	6-2
3	3.5-6.0	5.8	3-1	3-2	3-4	3-6
4	6.0-9.5	9.3	5-1	5-4	5-6	5-7
5	9.5-13.5	13.3	5-2	3-3	3-5	5-8
6	13.5-18.0	17.8	4-1	4-2	4-3	3-7

*Refer to schematic diagram, wiring diagram and marked photographs for location.

The alignment controls for the various bands are numbered on the chassis adjacent to the control. Controls for band 1 are marked 1, those for band 2 are marked 2, etc.

**Antenna alignment control knob on front panel.

e. Weak or No Signals On All Bands, C-W Reception (Modulated Reception Normal)

Weak or no signals on all bands for c-w reception with satisfactory modulated signal reception requires testing and alignment of the c-w oscillator. Proceed as outlined in paragraphs 35c (8) and 35c (9).

f. Measurements with Test Set I-56-C

The following readings are typical values obtained with Test Set I-56-C. If all plugs seem to be securely in position with the dynamotor running and faulty or poor operation is obtained from the receiver, a careful check should first be made of the cables and plugs using the 666 SC volt-ohmmeter as outlined under "Detailed Tests on Radio Sets", page 16 of the Instruction Book for Test Set I-56-C. If all plug-in cable connections seem to be functioning properly, a test should be made of the tubes in the receiver using the tube tester as outlined in the same paragraphs as mentioned in above. Should neither of these tests locate the difficulty, voltage and current or resistance measurements should be made as outlined in the following paragraphs:

(1) Voltage and Current Measurements

Set up the receiver and analyzer of Test Set I-56-C for operation as outlined under general voltage and current measurements. To obtain the various readings, connect the jumper leads from the socket selector block to the analyzer pin jacks in accordance with the instructions given below.

Procedure:

1. Release the thumb screws and pull the complete chassis out of the case.
2. Power connections should be made to the plug socket at the rear of the receiver chassis.
3. Be sure the plug and tube top grid connections are secure when taking readings.
4. Keep the analyzer AC-DC switch on DC.
5. Place the analyzer left-hand toggle switch in the VOLTS-MA position.
6. Connect the short jumper cables for the various tests as indicated in the table below.
7. Connect jumper cable from block terminal GND to receiver chassis.
8. Set the receiver control switch on the MVC position unless otherwise specified.
9. Set the receiver with the volume control at the maximum position (extreme clockwise).
10. Set the tuning control to 200 kc (1-f end of band 1); readings should deviate but slightly when switching to other bands with the tuning control remaining at the low frequency end of each band.
11. The c-w oscillator should be OFF for the readings in Table A and ON for the readings in Table B.

MAINTENANCE

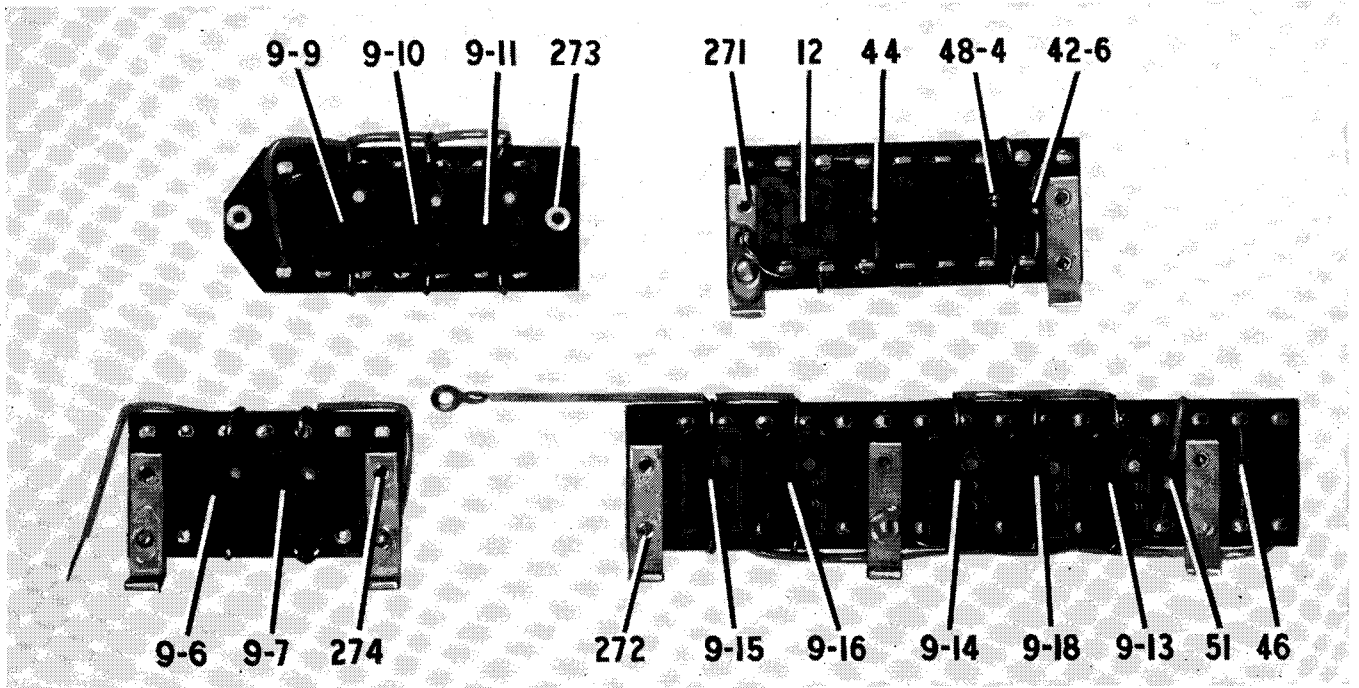

FIGURE 27—RESISTOR BOARDS FRONT VIEW

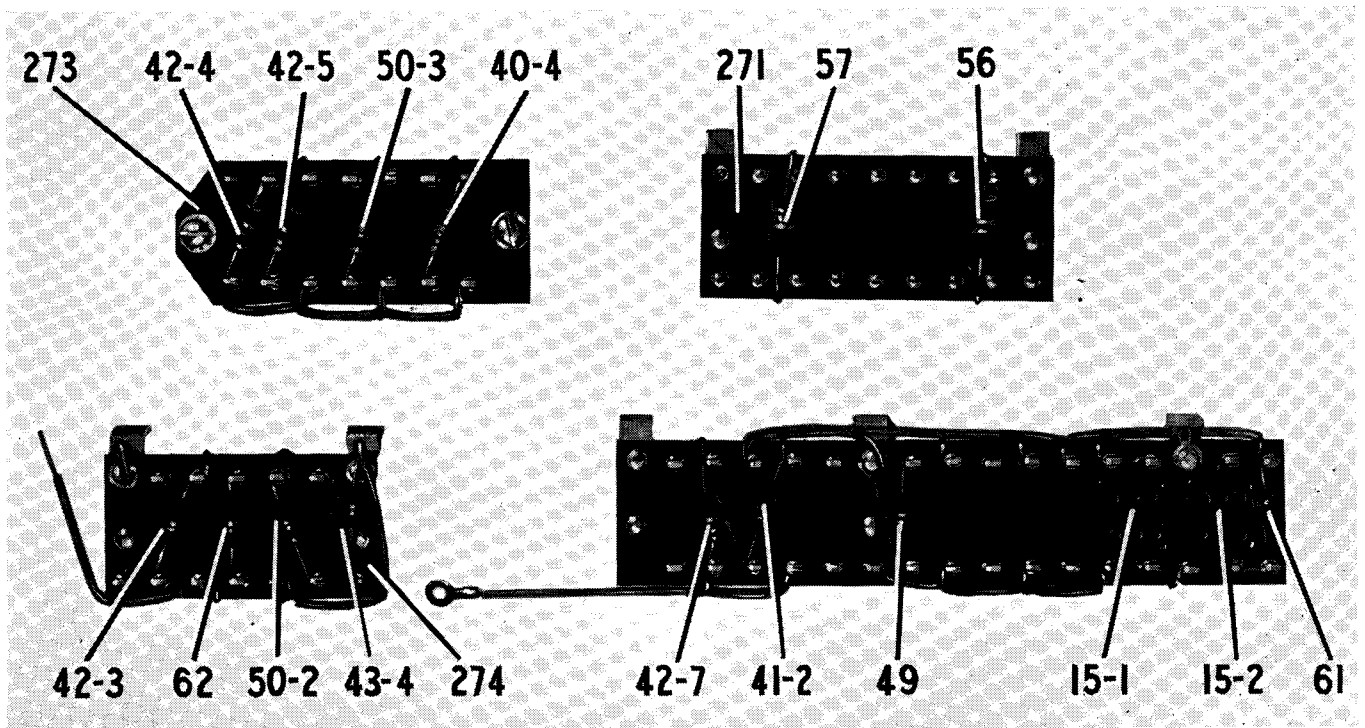

FIGURE 28—RESISTOR BOARDS REAR VIEW

NOTE: The readings given below are average values taken on receivers of this type using a 28-volt power supply. Meter indications within $\pm 10\%$ of these values will in most cases indicate correct operation.

In using the analyzer on the oscillator stage, precautions must be observed in order to assure that voltage and current measurements are made under actual operating conditions. The analyzer plug and adapter are plugged into the oscillator tube socket contained within the box and the tube placed in the appropriate analyzer socket. Before measurements may be made, it should be ascertained that voltage regulator tube 991 is functioning, as indicated by a glow within the tube. The switch should be set so as to select the #1 (lowest frequency) band and the dial adjusted to 200 kc. It is necessary that these steps be taken in order to

insure that oscillations are sustained during measurement. With the analyzer arranged to measure oscillator plate current and with the band switch and dial set as described, an oscillating condition should be obtained, which may be demonstrated by placing a finger tip upon the stator section of the oscillator tuning condenser, 1-D. If placing the finger tip upon this stator (insulated) section causes an increase in plate current, this shows that the oscillator was functioning until disturbed manually. The higher value of plate current represents the non-oscillating condition, which will probably be duplicated by switching to any other band, because the inter-electrode capacities contained within the analyzer connecting cable are of such magnitude as to make it impossible for the oscillator to function on the higher frequency.

TABLE A. C-W OSC. OFF

Stage	Tube	Plate Volts	Screen Volts	Cathode Volts	Heater Volts	Plate Current MA	Screen Current MA
1 R-F	VT-86	184	70	2.6	6.3	4.1	1.0
2 R-F	VT-86	186	86	3.2	6.3	4.8	1.3
1 Det.	VT-91	215	96	4.8	6.3	0.23	0.08
Osc.	VT-65	58	..	0.0	6.3	2.0
1 I-F	VT-86	202	82	2.3	6.5	3.6	1.2
2 I-F	VT-70	225	82	3.1	6.5	4.5	1.4
3 I-F	VT-93	207	72	21.0	6.5	2.5	0.6
Output	VT-48	197	207	0.0	6.5	18.0	3.2
2 Det.	VT-93 Diode	8.0					

TABLE B. C-W OSC. ON

Stage	Tube	Plate Volts	Screen Volts	Cathode Volts	Heater Volts	Plate Current MA	Screen Current MA
1 R-F	VT-86	197	37	1.3	6.3	2.0	0.55
2 R-F	VT-86	232	65	2.3	6.3	3.7	1.0
1 Det.	VT-91	204	72	3.4	6.3	0.17	0.06
Osc.	VT-65	58	..	0.0	6.3	1.6
1 I-F	VT-86	195	44	1.6	6.5	2.3	0.5
2 I-F	VT-70	210	44	1.6	6.5	2.2	0.5
3 I-F	VT-93	210	72	21.0	6.5	2.5	0.6
Output	VT-48	198	210	0.0	6.5	23.5	3.6
C-W Osc.	VT-70 Triode	18.0					

(2) Resistance and Continuity Measurements

Remove the chassis from the cabinet and do not make any connections to the plug socket at the rear of the chassis. This procedure permits the operation of all switches without running the dynamotor and causing voltages to be built up across the various resistors and condensers. Any voltages set up by the dynamotor in the receiver would cause serious errors in reading on the ohmmeter ranges or might possibly damage the test instruments. Procedure:

1. Set the receiver control switch to MVC unless otherwise specified.
2. Set the receiver with the volume control at the maximum position (extreme clockwise).
3. Set the tuning control to 200-500 kc (l-f end of band 1); readings should not deviate when switching to other bands with the tuning control remaining at the low frequency end of each band.
4. The c-w oscillator should be OFF for the readings in Table C and ON for the readings in Table D.
5. Shift the analyzer left-hand toggle switch to the ohms position.

Set up the Analyzer for resistance and continuity measurements as outlined under "General Resistance and Continuity

Tests" in the test set instruction book. Before taking a resistance reading on any range, short the two jumper leads plugged into the ohmmeter pin jacks and rotate the "battery adjustment" knob until the instrument pointer reads exactly full scale. Should it be found impossible to bring the pointer up to the top mark refer to the paragraphs on battery replacement under the heading "Maintenance" in the test set instruction book. Plug the pin tip end of the 3 foot clip lead into the block hole marked GND and clip the other end to the chassis. Connect one of the jumper leads between the remaining ground jack and one of the ohmmeter jacks on the required range. Connect the other jumper lead from the remaining ohmmeter range jack to the tube element under test. In general, ohmmeter readings will be most accurate when taken on the upper 2/3 of the scale and wherever possible, the range should be chosen that will give indications in this area.

g. Failure of Dial Lights

The two dial lamps are connected in series. Hence, the failure of either lamp does not necessarily indicate failure of both lamps. Removal of the dial light housing gives ready access to the lamps.

NOTE: The readings tabulated below are average values taken on receivers of this type with the storage battery disconnected. Meter indications within plus or minus 10% of these values will, in most cases, indicate correct operation.

Resistance to Ground (Ohms)

TABLE C. C-W OSC. OFF

Stage	Tube	Cathode	Plate	Screen	MVC Grid	AVC Grid
1 R-F	VT-86	490	5,200	80,000	100,000	1.8 meg.
2 R-F	VT-86	480	5,200	75,000	100,000	1.8 meg.
1 Det. Osc.	VT-91	15,000	5,600	75,000	0	0
	VT-65	0	41,000	100,000	100,000
1 I-F	VT-86	520	5,600	70,000	500,000	1.8 meg.
2 I-F	VT-70	470	500	70,000	500,000	2.25 meg.
3 I-F	VT-93	6,200	500	180,000	5,000	5,000
Output	VT-48	0	1,080	480	700,000	

TABLE D. C-W OSC. OFF

Stage	Tube	Cathode	Plate	Screen	MVC Grid	AVC Grid
1 R-F	VT-86	490	5,200	20,000	100,000	1.8 meg.
2 R-F	VT-86	480	5,200	23,000	100,000	1.8 meg.
1 Det.	VT-91	15,000	5,600	23,000	0	0
Osc.	VT-65	0	41,000	100,000	100,000
1 I-F	VT-86	520	5,600	9,200	500,000	1.8 meg.
2 I-F	VT-70	470	500	9,200	500,000	2.25 meg.
3 I-F	VT-93	6,200	500	180,000	5,000	5,000
Output	VT-48	0	1,080	480	700,000
C-W Osc.	VT-70	82,000	500,000
Det. Diode	VT-93	180,000
AVC Diode	VT-93	380,000

h. Performance Characteristics

Note	Test	Specification Performance	Average Performance
1	Sensitivity	less than 7. microvolts	1.2 microvolts
	Receiver sensitivity should be better than 20. microvolts at 20 volts d-c primary input to the receiver.		
2	Audio Power Output:		
	MVC	400 milliwatts	590 milliwatts
	AVC	200 milliwatts	830 milliwatts
3	Receiver Noise:	less than 15 milliwatts	0.8 milliwatts
4	Audio Hum:	less than 50 microwatts	
5	Selectivity:		
	Input Ratio (Input off Resonance)		
	(Input at Resonance)	Bandwidth (KC)	Bandwidth (KC)
	2:1	{200-500 kc }1.5-18.0 mc	2.1 min., 10 max. 3.0
	10:1		5 min., 10 max. 7.6
	100:1		18 max. 13.8
	1000:1		30 max. 19.1
	10,000:1		40 max. 26.2
			52 max. 32.4

CONNECTION CHART FOR USE OF TEST SET I-56-C USING ADAPTER FT-211.

Test	Tube	Function	Block Terminal Number	to	Analyzer Jacks	
Plate Voltage	VT-86	R-F & I-F Ampl.	3	gnd	250 V ± V	
	VT-91	1st Det.				
	VT-93	3rd I-F	2	gnd	250 V ± V	
	VT-65	R-F Osc.				
	VT-48	Audio				
Screen Voltage	VT-70	2nd I-F	4	gnd	250 V ± V	
	VT-86	R-F & I-F Ampl.				
	VT-91	1st Det.	3	gnd	250 V ± V	
	VT-48	Output				
	VT-70	2nd I-F, C-W Osc.				
Cathode Voltage	VT-93	3rd I-F	6	gnd	250 V ± V	
	VT-86	R-F & I-F Ampl.				
	VT-91	1st Det.	8	gnd	10 V ± V	
	VT-65	R-F Osc.				
	VT-70	2nd I-F, C-W Osc.				
	Heater Voltage	VT-93	3rd I-F, 2nd Det.	8	gnd	25 V ± V
		VT-48	Output			
VT-65		R-F Osc.	7	gnd	10 V ± V	
VT-86		1st R-F, 2nd R-F				
VT-91		1st Det.				
VT-93		3rd I-F				
Triode Voltage		VT-86	1st I-F	2	7	10 V ± V
	VT-70	2nd I-F				
	Diode Voltage	VT-48	Output	6	1	10 V ± V
		VT-70	C-W Osc.			
		VT-93	2nd Det.	5	gnd	250 V ± V
VT-86	R-F & I-F Ampl.					
Plate Current	VT-91	1st Det.	3 outside	3 inside	10 ma. - ma.	
	VT-65	R-F Osc.				
	VT-93	3rd I-F, 2nd Det.	2 outside	2 inside	25 ma. - ma.	
	VT-48	Output				
	Screen Current	VT-70	2nd I-F, C-W Osc.	2 outside	2 inside	10 ma. - ma.
VT-86		R-F & I-F Ampl.				
VT-91		1st Det.	4 outside	4 inside	10 ma. - ma.	
VT-48		Output				
VT-70		2nd I-F, C-W Osc.	3 outside	3 inside	10 ma. - ma.	
VT-93	3rd I-F, 2nd Det.					
			6 outside	6 inside	1 ma.	

REFERENCE NOTES

(for Performance Characteristics)

NOTE 1. Sensitivity shall be measured as follows:

The radio receiver is to be operated at 28 volts with a 4000 ohm non-inductive output load. The calibrated signal generator output is to be fed to the receiver through a 100 mmf mica capacitor. Antenna trimmer alignment is to be made at 3.4 mc. only, and before sensitivity measurements are taken.

A. For MCW measurements turn C-W OSC. switch OFF and CRYSTAL switch OUT. Adjust the standard signal generator to give approximately 10 milliwatts receiver output at the resonant frequency. Alternately adjust the receiver INCREASE VOL. control and the signal generator attenuator to obtain 10 milliwatts receiver output with a 400 cycle 30% modulated signal and 2.5 milliwatts noise output with the unmodulated carrier applied to the receiver. Read microvolts sensitivity on the signal generator attenuator. If noise adjustment is not necessary set receiver INCREASE VOL. control at maximum.

B. For C-W Measurements turn C-W OSC. switch ON and CRYSTAL switch OUT. Adjust the receiver volume control to give 0.3 milliwatt noise output, if possible, with no signal input. With an unmodulated carrier

input and the receiver BEAT FREQ. control adjusted for approximately 800 cycles the signal generator attenuator shall be adjusted to obtain a receiver output of 10 milliwatts. Read microvolts sensitivity on the signal generator attenuator.

NOTE 2. Audio power output shall be measured into a 4000 ohm non-inductive load and with a 400 cycle 30% modulated signal input. Receiver input voltage shall be held at 28 volts.

NOTE 3. Receiver noise shall be measured with a 4000 ohm load, with a 28 volt primary power input, and with the INCREASE VOL. control at maximum. A 100 mmf mica capacitor shall be connected between antenna and ground terminals of the receiver.

NOTE 4. Audio hum is to be measured using a 4000 ohm load, with a 28 volt primary power input and with the INCREASE VOL. control at minimum.

NOTE 5. The selectivity of the receiver on MVC with the CRYSTAL switch OUT shall comply with the values given in the table when measured at normal sensitivity by the single standard signal generator method.

SECTION V
APPENDIX

36. TABLE OF REPLACEABLE PARTS

Reference No.	Signal Corps. Stock No.	Name of Part	Description	Function	Mfg. Symbol	Dwg. No.
1-A	3D9016V-2	Capacitor	A Section, 16 to 331 mmfd $\pm 0.5\%$ Special	Main Tuning	RC	D-5024
1-B			B Section, 16 to 331 mmfd $\pm 0.5\%$ Special			
1-C			C Section, 16 to 331 mmfd $\pm 0.5\%$ Special			
1-D			D Section, 16 to 331 mmfd $\pm 0.5\%$ Special			
2	3DF104	Capacitor	Air Trimmer 50 mmfd max; Type APC Special	Antenna Coupling	RC, AW, OM	D-3450
3-1	3DF99	Capacitor	Air Trimmer 50 mmfd max; Type APC	Antenna Unit Trimmer	OM, RC, AW	D-3458
3-2				R-F Unit Trimmer		
3-3				R-F Unit Trimmer		
3-4				1st Det. Unit Trimmer		
3-5				1st Det. Unit Trimmer		
3-6				Osc. Unit Trimmer		
3-7				Osc. Unit Trimmer		
4-1	3DF101	Capacitor	Air Trimmer 50 mmfd max; Type APC	Antenna Unit Trimmer	OM, RC, AW	D-3448
4-2				R-F Unit Trimmer		
4-3				1st Det. Unit Trimmer		
5-1	3DF100	Capacitor	Air Trimmer 25 mmfd max; Type APC	Antenna Unit Trimmer	RC, AW, OM	D-3455
5-2				Antenna Unit Trimmer		
5-3				R-F Unit Trimmer		
5-4				R-F Unit Trimmer		
5-5				1st Det. Unit Trimmer		
5-6				1st Det. Unit Trimmer		
5-7				Osc. Unit Trimmer		
5-8				Osc. Unit Trimmer		

APPENDIX

Reference No.	Signal Corps. Stock No.	Name of Part	Description	Function	Mfg. Symbol	Dwg. No.
6-1	3DF105	Capacitor	Air Trimmer 25 mmfd max; Type APC	Osc. Unit Trimmer	RC, AW, OM	D-3535
6-2				Osc. Unit Trimmer		
7	3DF103	Capacitor	Air Trimmer 10 mmfd max; Type APC	Crystal Filter Adjustment	FWS	D-3823
8	3DF102	Capacitor	Air Trimmer 10 mmfd max; Type APC Special	C-W Osc. Freq. Adjustment	FWS	D-3809
9-1	3DA10-44	Capacitor	Paper, 400 V D-C, 0.01 mfd $\pm 20\%$ with Leads MR Type 340 SMC Type MPW	1st R-F Cathode By-pass	SMC, MR	D-3682
9-2				1st R-F Screen By-pass		
9-3				2nd R-F Cathode By-pass		
9-4				2nd R-F Screen By-pass		
9-5				1st Det. Screen By-pass		
9-6				1st I-F Transformer By-pass		
9-7				Crystal Filter Transformer		
9-8				1st I-F Cathode By-pass		
9-9				1st I-F Plate By-pass		
9-10				2nd I-F Transformer By-pass		
9-11				2nd I-F Cathode By-pass		
9-12				C-W Osc. Plate By-pass		
9-13				Plug Terminal By-pass		
9-14				AVC By-pass		
9-15				3rd I-F Transformer By-pass		
9-16				3rd I-F Cathode By-pass		
9-17				Heater By-pass		
9-18				Battery By-pass		

TABLE OF REPLACEABLE PARTS

Reference No.	Signal Corps. Stock No.	Name of Part	Description	Function	Mfg. Symbol	Dwg. No.
10-1	3DA10-44	Capacitor	Paper, 400 V D-C, 0.01 mfd $\pm 20\%$ with leads MR Type 340 SMC Type MPW	Antenna Coil By-pass	SMC, MR	D-3682
10-2				R-F Plate By-pass		
10-3				R-F Coil By-pass		
10-4				2nd R-F Plate By-pass		
11-1	3DA10-44	Capacitor	Paper, 400 V D-C, 0.01 mfd $\pm 20\%$ with leads MR Type 340 SMC Type MPW	Heterodyne Osc. Plate By-pass	SMC, MR	D-3682
11-2				1st Det. Cathode By-pass		
12	3DA5-18	Capacitor	Paper, 500 V D-C, .005 mfd $\pm 20\%$ with leads MR Type 340 SMC Type MPW	Audio Transformer Secondary By-pass	SM, MR	D-3932
13	3D9375	Capacitor	Mica, 500 V D-C, 375 mmfd $\pm 1.5\%$ with leads, CD Type 5R, A Type 1464, MR Type PO, ER Type K	Osc. Series	MR, A, ER, CD	D-4383
14	3DA2-240	Capacitor	Mica, 500 V D-C, 2240 mmfd $\pm 5\%$ with leads, CD Type 1R, or A Type 1464	Osc. Series	MR, A, CD, ER	D-3564...
15-1		Capacitor	Paper, 500 V D-C, 1500 mfd $\pm 20\%$ with leads MR Type 340 SMC Type MPW	Audio Coupling Condenser	MR, SMC	D-3941
15-2				Audio Transformer Primary By-pass		

APPENDIX

Reference No.	Signal Corps. Stock No.	Name of Part	Description	Function	Mfg. Symbol	Dwg. No.
16	3D9670	Capacitor	Mica, 500 V D-C, 670 mmfd $\pm 1.5\%$ with leads, CD Type 1R, or A Type 1464	Osc. Series	CD, MR, ER	D-4391
17	3D9147	Capacitor	Mica, 500 V D-C, 147 mmfd $\pm 1\%$ with leads, CD Type 5R, ER Type K, MR Type O	Osc. Series	CD, ER, MR	D-4379
18-1		Capacitor	Mica, 500 V D-C, 500 mmfd $\pm 5\%$ with leads, CD Type 5R, ER Type K	1st I-F Transformer Secondary Tuning	CD, ER, MR, FWS	D-3778
18-2				1st I-F Transformer Secondary Tuning		
19		Capacitor	Mica, 500 V D-C, 290 mmfd $\pm 1\%$ with leads, CD Type 5R, ER Type K	Crystal Transformer Tuning	CD, MR, ER FWS	D-3824
20-1		Capacitor	Mica, 500 V D-C, 260 mmfd $\pm 5\%$ with leads, CD Type 5R, ER Type K	2nd I-F Transformer Primary Tuning	CD, MR, ER FWS	D-3775
20-2				2nd I-F Transformer Secondary Tuning		
20-3				3rd I-F Transformer Secondary Tuning		
21-1	3D9250-18	Capacitor	Mica, 500 V D-C, 250 mmfd $\pm 5\%$ with leads, CD Type 5R, ER Type K	1st I-F Transformer Primary Tuning	CD, MR, ER FWS	D-3774
21-2				3rd I-F Transformer Primary Tuning		
21-3				R-F Unit Padder		

TABLE OF REPLACEABLE PARTS

Reference No.	Signal Corps. Stock No.	Name of Part	Description	Function	Mfg. Symbol	Dwg. No.
22-1	3D9168	Capacitor	Mica, 500 V D-C, 240 mmfd $\pm 5\%$ with leads, CD Type 5R, ER Type K	C-W Osc. Padding	CD, MR, ER FWS	D-3813
22-2				2nd Det. By-pass		
23	3D9240	Capacitor	Mica, 500 V D-C, 168 mmfd $\pm 1.2\%$ with leads, CD Type 5R, ER Type K, MR Type O	Osc. Series	CD, MR, ER	D-4372
24-1	3D9155	Capacitor	Mica, 500 V D-C, 155 mmfd $\pm 1.8\%$ with leads, CD Type 5R, ER Type K	Antenna Series	CD, ER, MR	D-4043
24-2				2nd R-F Series		
24-3				1st Det. Series		
25	3D9025-30	Capacitor	Mica, 25 mmfd $\pm 5\%$, CD Type 5R, CD Type O, ER Type K	Antenna Unit Padder	CD, MR, ER	D-4398
26-1		Capacitor	Mica, 500 V D-C, 150 mmfd $\pm 5\%$ with leads, CD Type 5R, ER Type K	C-W Osc. Grid	CD, MR, ER	D-3776
26-2				4th I-F Transformer Secondary Tuning		
27	3D9134	Capacitor	Mica, 500 V D-C, 134 mmfd $\pm 1\%$ with leads, CD Type 5R, ER Type K, MR Type O	Heterodyne Osc. Series	CD, MR, ER	D-4357

APPENDIX

Reference No.	Signal Corps. Stock No.	Name of Part	Description	Function	Mfg. Symbol	Dwg. No.
28-1	3D9135	Capacitor	Mica, 500 V D-C, 135 mmfd $\pm 2\%$ with leads, CD Type 5R, ER Type K, MR Type PO	Antenna Unit Series	CD, MR, ER,	D-4042
28-2				R-F Unit Series		
28-3				1st Det. Unit Series		
29-1	3D9460	Capacitor	Mica, 500 V D-C, 460 mmfd $\pm 2\%$ with leads, CD Type 5R, ER Type K, MR Type O	Antenna Unit Padding	CD, MR, ER	D-4371
29-2				R-F Unit Padding		
29-3				1st Det. Unit		
30	3D9100-19	Capacitor	Mica, 500 V D-C, 100 mmfd $\pm 5\%$ with leads, CD Type 5R, ER Type K	Heterodyne Osc. Grid	CD, MR, ER	D-4044
31-1	3D9075-2	Capacitor	Mica, 500 V D-C, 75 mmfd $\pm 5\%$ with leads, CD Type 5R, ER Type K	R-F Padding	CD, MR, ER	D-4040
31-2				1st Det. Padding		
31-3				Diode Coupling		
32		Capacitor	Mica, 500 V D-C, 47 mmfd $\pm 5\%$ with leads, CD Type 5R, ER Type K	4th I-F Transformer Primary Tuning	CD, MR, ER	D-3777
33-1	3D9050-7	Capacitor	Mica, 500 V 50 mmfd $\pm 5\%$ with leads, CD Type 5R, MR Type O, ER Type K	Antenna Unit Padder	CD, MR, ER	D-4370
33-2				2nd R-F Unit Padder		
33-3				1st Det. Unit Padder		

TABLE OF REPLACEABLE PARTS

Reference No.	Signal Corps. Stock No.	Name of Part	Description	Function	Mfg. Symbol	Dwg. No.
34	3D9085	Capacitor	Ceramic 500 V 85 mmfd ±2.5% with leads, ER Type NPOM	Osc. Temperature Compensating	ER	D-4053
35	3D9047-1	Capacitor	Ceramic 500 V 47 mmfd ±5% with leads, CRL Type 813 ZTC	Osc. Temperature Compensating	CRL	D-4052
36	3D9027-1	Capacitor	Ceramic, 500 V 27 mmfd ±2.5% with leads, ER Type N680K	Osc. Temperature Compensating	ER	D-4055
37-1	3DF98	Capacitor	Air Trimmer 25 mmfd Max. APC	Band 1 R-F Trimmer	RC, AW, OM	D-5023
37-2				Band 1 1st Det. Trimmer		
38-1A	3DA500-60	Capacitor	Oil, 250 V D-C, 0.5 mfd ±15%	4th I-F Transformer Filter	SS, MR	D-3933
38-1B				Volume Control Filter		
38-2A				Screen Voltage Filter		
38-2B				Output Plate Filter		
38-3A				Noise Compensator		
38-3B				1st I-F Screen Filter		
39-1A	3DA500-61	Capacitor	Oil, 250 V D-C, 0.5 mfd ±15%	4th I-F Transformer Filter	SS, MR	D-2334
39-1B				4th I-F Transformer Filter		
39-2A				Output Grid Filter		
39-2B				Screen Voltage Filter		
39-3A				1st I-F Screen Filter		
39-3B				3rd I-F Screen Filter		
40-1	3Z6047-5	Resistor	Insul. 470 ohms ±10% ½W, Type EB	1st R-F Cathode	AB	P-28154
40-2				2nd R-F Cathode		
40-3				1st I-F Cathode		
40-4				2nd I-F Cathode		

APPENDIX

Reference No.	Signal Corps. Stock No.	Name of Part	Description	Function	Mfg. Symbol	Dwg. No.
41-1	3Z6100-58	Resistor	Insul. 1,000 ohms $\pm 10\%$ $\frac{1}{2}$ W, Type EB	Osc. Plate	AB	P-28158
41-2				3rd I-F Cathode		
41-3				1st R-F Primary		
42-1	3Z6470-8	Resistor	Insul. 4,700 ohms $\pm 10\%$ $\frac{1}{2}$ W, Type EB	1st R-F Plate	AB	P-28166
42-2				2nd R-F Plate		
42-3				1st Det. Plate		
42-4				1st I-F Screen		
42-5				1st I-F Plate		
42-6				Bleeder		
42-7				3rd I-F Cathode		
42-8				Voltage Regulator Series		
43-1	3Z4529	Resistor	Insul. 10,000 ohms $\pm 10\%$ $\frac{1}{2}$ W, Type EB	1st R-F Screen	AB	P-28170
43-2				2nd R-F Screen		
43-3				1st Det. Screen		
43-4				C-W Osc. Bleeder		
45	3Z4614	Resistor	Insul. 15,000 ohms $\pm 10\%$ $\frac{1}{2}$ W, Type EB	1st Det. Cathode	AB	P-28172
46	3Z6656-1	Resistor	Insul. 56,000 ohms $\pm 10\%$ $\frac{1}{2}$ W, Type EB	Output Loading	AB	P-28178
47	3Z6668	Resistor	Insul. 68,000 ohms $\pm 10\%$ $\frac{1}{2}$ W, Type EB	C-W Osc. Plate	AB	P-28179
48-1	3Z6700-61	Resistor	Insul. 100,000 ohms $\pm 10\%$ $\frac{1}{2}$ W, Type EB	1st R-F Grid	AB	P-28006
48-2				2nd R-F Grid		
48-3				Osc. Grid		
48-4				Output Grid Filter		
48-5				Bias Control		

TABLE OF REPLACEABLE PARTS

Par. 36

Reference No.	Signal Corps. Stock No.	Name of Part	Description	Function	Mfg. Symbol	Dwg. No.
49	3Z6718	Resistor	Insul. 180,000 ohms ±10% ½ W, Type EB	3rd I-F Screen	AB	P-28182
50-1	3Z6747-9	Resistor	Insul. 470,000 ohms ±10% ½ W, Type EB	Antenna Protective	AB	P-28187
50-2				1st I-F Grid		
50-3				2nd I-F Grid		
50-4				C-W Osc. Grid		
51	3Z6756-6	Resistor	Insul. 560,000 ohms ±10% ½ W, Type EB	Output Grid	AB	P-28188
52	3Z6801A5-6	Resistor	Insul. 1.5 megohms ±10% ½ W, Type EB	AVC Diode	AB	P-28193
53	3Z6722-5	Resistor	Insul. 220,000 ohms ±10% ½ W, Type EB	AVC Filter	AB	P-28183
56	3Z6610-59	Resistor	Insul. 10,000 ohms ±10% 1 W, Type G	Bleeder	AB	P-30417
57	3Z6627-8	Resistor	Insul. 27,000 ohms ±10% 1 W, Type G	Voltage Regulator Series Resistor	AB	P-34578
58	3Z6350V-4	Resistor	Variable 3,500 ±10% to 10 ohms 0.1 W, Special	Noise Compensator	CTS, IRC	D-3673
59-A	2C4348M/R1	Resistor	Vol. Control Front Unit, 20,000 ±10% to 10 ohms, 2.0 W Special	MVC	AB, CTS	D-3717
59-B			Vol. Control Back Unit 350,000 ±10% to 50 ohms, 0.2 W	AVC		
61	3Z6240	Resistor	Insulated, 2,400 ohms ±5%, ½ W, Type EB, or 1 W Type G.	Output Plate	AB	P-34650 D-5783

APPENDIX

Reference No.	Signal Corps. Stock No.	Name of Part	Description	Function	Mfg. Symbol	Dwg. No.
62	3Z6647-1	Resistor	Insulated, 47,000 ohms ±10%, ½W, Type EB	Bleeder	AB	P-28177
63	3Z6006H4	Resistor	Insulated, 68 ohms ±10% ½W, Type EB	AVC Compensating	AB	P-28144
64	3D9035-3	Capacitor	Ceramic, 500 V, 35 mmfd-2.5% with leads, ER Type NPOM	Osc. Unit Padder	ER	D-4380
65	3DF97	Capacitor	Air Trimmer 10 mmfd, Special	Ant. Unit Trimmer	RC, OM, AW	D-3562
66-1*		Capacitor	Mica, 500 Volts, 20 mmfd ±20% MR, Type O	Part of 82	MR	D-5715
66-2*				Part of 88	MR	D-5715
71		Inductance	Ant. Band 1	1st R-F Tuned Circuit		D-4358
72			Ant. Band 2	1st R-F Tuned Circuit		D-4360
73			Ant. Band 3	1st R-F Tuned Circuit		D-4362
74			Ant. Band 4	1st R-F Tuned Circuit		D-4364
75			Ant. Band 5	1st R-F Tuned Circuit		D-4366
76			Ant. Band 6	1st R-F Tuned Circuit		D-4368
77		Transformer	R-F Band 1	1st R-F to 2nd R-F Coupling		D-4384
78			R-F Band 2	1st R-F to 2nd R-F Coupling		D-4385
79			R-F Band 3	1st R-F to 2nd R-F Coupling		D-4386
80			R-F Band 4	1st R-F to 2nd R-F Coupling		D-4387
81			R-F Band 5	1st R-F to 2nd R-F Coupling		D-4388
82			R-F Band 6	1st R-F to 2nd R-F Coupling		D-4389

* Used on Radio Receiver BC-348-P (File 2542-WF-42) only.

TABLE OF REPLACEABLE PARTS

Reference No.	Signal Corps. Stock No.	Name of Part	Description	Function	Mfg. Symbol	Dwg. No.
83		Transformer	1st Det. Band 1	2nd R-F to 1st Det. Coupling	FWS	D-4373
84			1st Det. Band 2	2nd R-F to 1st Det. Coupling	FWS	D-4374
85			1st Det. Band 3	2nd R-F to 1st Det. Coupling	FWS	D-4375
86			1st Det. Band 4	2nd R-F to 1st Det. Coupling	FWS	D-4376
87			1st Det. Band 5	2nd R-F to 1st Det. Coupling	FWS	D-4377
88			1st Det. Band 6	2nd R-F to 1st Det. Coupling	FWS	D-4378
89			Osc. Band 1	Osc. to 1st Det. Coupling	FWS	D-4392
90			Osc. Band 2	Osc. to 1st Det. Coupling	FWS	D-4393
91			Osc. Band 3	Osc. to 1st Det. Coupling	FWS	D-4394
92			Osc. Band 4	Osc. to 1st Det. Coupling	FWS	D-4395
93			Osc. Band 5	Osc. to 1st Det. Coupling	FWS	D-4396
94			Osc. Band 6	Osc. to 1st Det. Coupling	FWS	D-4397
95		Transformer	1st I-F	1st Det. to Crystal Coupling	FWS	D-3753
96			Crystal Filter	Crystal to 1st I-F Coupling	FWS	D-3817
97			2nd I-F	1st I-F to 2nd I-F Coupling	FWS	D-3754
98			C-W Osc.	Grid and Plate Coupling	FWS	D-3795
99			3rd I-F	2nd I-F to 3rd I-F Coupling	FWS	D-3755
100			4th I-F	3rd I-F to 2nd Det. Coupling	FWS	D-3756
101-A	2C4348M/T2	Transformer	Audio	Output	CT, AEM, ST	D-3560
101-B		Choke	Audio Frequency	Filter		
101-C		Capacitor	Paper 0.05 mfd $\pm 10\%$ 400 V D-C	C-W Osc. Time Constant		

APPENDIX

Reference No.	Signal Corps. Stock No.	Name of Part	Description	Function	Mfg. Symbol	Dwg. No.
102-1	2C4348M/J1	Jack	Single Circuit	Headphone	PRM	D-3726
102-2			Single Circuit	Headphone		
103	2V991	Regulator	Neon Bulb RCA 991	Osc. Plate Volt Regulator	RCA	
104	2Z5927	Dial Lamp LM-27	6 to 8 V. GE-44 Mazda	Illuminates Dial	WE-GE	D-3866
105	3Z9692-1561.1	Switch	SPST Type 1561-KC	Crystal Filter (OUT-IN)	AHH	D-3819
106	3Z9858-1	Switch	DPST Type 81009	C-W Osc. (ON-OFF)	AHH	D-3734
107	3Z9825-1	Switch	3 Positions, 2 Wafers, Type 15824-H2	AVC-OFF-MVC	OM	D-3719
108	3Z9693-2	Switch	6 Position, 1 Wafer	Band Switch Antenna Unit	PRM, OM	D-3489
109	3Z9693-1		6 Position, 1 Wafer	Band Switch Antenna Unit		
110			6 Position, 1 Wafer	Band Switch R-F Unit		
111			6 Position, 1 Wafer	Band Switch R-F Unit		
112			6 Position, 1 Wafer	Band Switch Det. Unit		
113			6 Position, 1 Wafer	Band Switch Det. Unit		
114	3Z9693-1	Switch Assembly	6 Position, 1 Wafer	Band Switch Osc. Unit	PRM, OM	D-3519
115			6 Position, 1 Wafer	Band Switch Osc. Unit		
116			6 Position, 1 Wafer	Band Switch Osc. Unit		
117			6 Position, 1 Wafer	Band Switch Osc. Unit		
119	3Z635	Binding Post	Panel	Antenna	ARH	D-3961
120	3Z635-1	Binding Post	Panel	Ground	ARH	D-3718
121		Crystal Assembly	915 KC Crystal in Moulded Case	I-F Filter	FWS	D-3828
201	2C4348M/HL	Handle	Panel, modified, Type 0130.	Carrying	NL	D-3727

TABLE OF REPLACEABLE PARTS

Reference No.	Signal Corps. Stock No.	Name of Part	Description	Function	Mfg. Symbol	Dwg. No.
202	2Z6190	Lever	Control	AVC-OFF-MVC		D-3735
203	2Z5748.1	Knob	Control	Antenna Alignment Crystal OUT-IN Switch, Dial Lamp Control and Volume Control		D-3714
204	2Z5748.2	Knob	Control	Beat Freq. Control		D-3716
205	2C4348M/S4	Thumb Screws	Dial Window	Holds Dial Window		D-3704
206	2Z5748.1	Knob	Control	Band Change		D-3709
207	2Z5748	Knob	Control	Main Tuning Cond.		D-3705
208	2C4348M/C3	Cover	Panel	Permits Access to Tube Shelf	ECE	D-3720
209	2C4348M/S6	Special Screw	Shouldered	Main Tuning Capacitor		D-3967
210	2C4348M/S7	Special Screw	Shouldered Flathead	Dynamotor Assembly to Mounting Plate		D-3922
211	2C4348M/S8	Special Screw	Captive	Dynamotor Assembly		D-3904
212	2C4348M/S9	Special Screw	Slotted Hex Head	Dial Assembly to Chassis		D-3986
213	2C4348M/S5	Special Screw	Shouldered	Secures Plug to Mounting Plate		D-4352
214	2C4348M/C4	Cover	Plate with Captive Screw	Covers tube in Osc. Unit	SG	D-3541
215	2C4348M/83	Shield	Tube, Shield Special	Shield for Tube VT-70	AG	D-3740
217	2Z8670.3	Socket	Tube, Octal, Type 6744-W1	For Tubes VT-91, VT-86, VT-93, VT-65	CM	D-3512
218	2C4348M/S1	Socket	Bayonet Type Special	For Voltage Regulator	CH	D-3955
219	2C8688-1	Socket	Tube, 6 Prong, Type Z-13W1	For Tube VT-48	CM	D-3836
220		Socket	Tube, 7 Prong, Type U-13W1	For Tube VT-70	CM	D-3837

APPENDIX

Reference No.	Signal Corps. Stock No.	Name of Part	Description	Function	Mfg. Symbol	Dwg. No.
221	3C4348M/S2	Socket	Lamp	For Dial Lamp	PRM	D-3870
222	2Z3084	Socket SO-104	8 Pole Male	Power Connections	AP	D-3849
251	2C4348M/T3	1st I-F Transformer Assembly	Complete with Shield Can Includes 18-1, 18-2, 21-1, 95	1st Det. to 1st I-F Coupling	FWS	D-3749
252	2C4348M/T4	2nd I-F Transformer Assembly	Complete with Shield Can Includes 20-1, 20-2, 97	1st I-F to 2nd I-F Coupling	FWS	D-3750
253	2C4348M/T5	3rd I-F Transformer Assembly	Complete with Shield Can Includes 20-3, 21-2, 99	2nd I-F to 3rd I-F Coupling	FWS	D-3751
254	2C4348M/T6	4th I-F Transformer Assembly	Complete with Shield Can Includes 26-2, 32, 100	3rd I-F to 2nd Det. Coupling	FWS	D-3752
255	2C4348M/F1	Crystal Filter Assembly	Complete with Shield Can Includes 7; 19, 96, 105, 121	Controls I-F Selectivity	FWS	D-3814
256	2C4348M/P5	C-W Osc. Assembly	Complete with Shield Can Includes 8, 9-12, 22-1, 26-1, 47, 98	C-W Reception	FWS	D-3791
257	2C4348M/A11	Antenna Unit Assembly	Complete with Shield Can Includes 2, 3-1, 3-2, 4-1, 5-1, 5-2, 10-1, 24-1, 28-1, 29-1, 31-1, 48-1, 71, 72, 73, 74, 75, 76, 108, 109	Antenna to 1st R-F Tube Coupling		D-3411
258	2C4348M/F13	R-F Unit Assembly	Complete with Shield Can Includes 3-3, 3-4, 4-2, 4-3, 5-3, 5-4, 10-2, 10-3, 24-2, 28-2, 29-2, 31-2, 42-1, 48-2, 77, 78, 79, 80, 81, 82, 110, 111	1st R-F to 2nd R-F Tube Coupling		D-3413

TABLE OF REPLACEABLE PARTS

Reference No.	Signal Corps. Stock No.	Name of Part	Description	Function	Mfg. Symbol	Dwg. No.
259	2C4348M/D12	Det. Unit Assembly	Complete with Shield Can Includes 3-5, 3-6, 4-4, 4-5, 5-5, 5-6, 10-4, 24-3, 28-3, 29-3, 31-3, 42-2, 83, 84, 85, 86, 87, 88, 112, 113	2nd R-F to 1st Det. Tube Coupling		D-3412
260	2C4348M/P6	Osc. Unit Assembly	Complete with Shield Can Includes 3-7, 3-8, 6-1, 6-2, 6-3, 6-4, 11-1, 11-2, 13, 14, 16, 17, 23, 27, 30, 33, 34, 35, 36, 37, 41-1, 45, 48-3, 89, 90, 91, 92, 93, 94, 114, 115, 116, 117, 214, 217	Heterodyne Osc. to 1st Det. Coupling		D-3414
271		Resistor Board	17 Terminals	Supports Parts 12, 42-6, 44, 48-4, 56, 57	CM	D-3927
272		Resistor Board	32 Terminals	Supports Parts 9-13, 9-14, 9-15, 9-16, 9-18, 15-1, 15-2, 41-2, 42-7, 46, 49, 51, 54, 61	CM	D-3938
273		Resistor Board	14 Terminals	Supports Parts 9-9, 9-10, 9-11, 40-4, 42-4, 42-5, 50-3	CM	D-3676
274		Resistor Board	14 Terminals	Supports Parts 9, 6, 43-4, 50-2, 55, 62	CM	D-3928
276		Dial Mechanism	Complete with Mask, Index, Gear Drive, Stop and Detent Mechanism	Frequency Indicator Tuning Condenser Drive	RMC	D-5029
301	2C4348M/C2	Choke	R-F	Filter for Dynamo		D-3909
302	2C4348M/C1	Choke	R-F	Filter for Dynamo		D-3908

APPENDIX

Reference No.	Signal Corps. Stock No.	Name of Part	Description	Function	Mfg. Symbol	Dwg. No.
303-A	3DA500-62	Capacitor	Oil, 250 V D-C, 0.5 mfd ±20%	Filter for Dynamotor	SS, MR	D-4033
303-B						
304-1		Capacitor	Paper, 400 V D-C, 0.01 mfd ±20% with leads	Filter for Dynamotor	SMC, MR	D-3682
304-2		Capacitor	MR Type 340, SMC Type MPW	Filter for Dynamotor		D-3492
305	3DH1.8129	Capacitor	Oil 1 mfd ±20% 400 V	Filter for Dynamotor	SS	D-3915
306		Capacitor	.01 mfd ±20% 400 V Paper, MR Type 340, SMC Type MPW	Dynamotor Filter	MR, SMC	D-3682
307		Bearing (Set of 2)	Part of Ref. 510	Dynamotor	WC	D-3472
308	3H1628M/B4	Brush and Spring	Part of Ref. 510	Pos. H-V	WC	D-4348
309	3H1628M/B4.1	Brush and Spring	Part of Ref. 510	Neg. H-V	WC	D-4349
315		End Bell	Part of Ref. 510	Low Voltage End Bearing	WC	
316		End Bell	Part of Ref. 510	High Voltage End Bearing	WC	
319		Tie Bars	Part of Ref. 510	Hold Items 315, 316 to Frame	WC	
320		Brush Caps	Part of Ref. 510	Holds Brushes	WC	
321		Grommet	Part of Ref. 510	Protects Terminal Wires	WC	
322		Gasket	Part of Ref. 510	Prevents Leakage of Lubricant	WC	
323		Plate	Part of Ref. 510	Bearing Retainer	WC	

TABLE OF REPLACEABLE PARTS

Reference No.	Signal Corps. Stock No.	Name of Part	Description	Function	Mfg. Symbol	Dwg. No.
324		Cover	Part of Ref. 510	Dust Cover		
350		Bracket and Gear Assembly	Pair of Beveled Gears and Coupling	Drives Band Change Switch		D-3685
351		Coupling	Flanged Collar with Rectangular Slot	Coupling Band Change Knob Shaft to Item 350		D-3661
352		Coupling Slide	Disk with Two Rectangular Keys	Slide Between 2 of Item 351		D-3693
353		Window Frame Assembly	Removable Cast Housing which Holds Dial Glass	Covers Dial Lamps		D-3699
355		Friction Spreader	Phosphorus Bronze Spring	Prevents Controls from Turning Under Vibration	SG	D-3713
356		Jack Cover Assembly	Spring Actuated Cover	Seals Jack Openings	CN	D-3721
357		Bushing	Threaded Bushing	Holds Handle to Panel and Provides Bearing for Thumb Screw		D-3728
358		Nut	Special Locking Nut	Holds Item 357		D-3729
359		Thumb Screw Assembly	No. 10-24 x 10 ¹ / ₈ inches Long (Special)	Holds Chassis in Cabinet		D-3730
360		Nut	Special Locking Nut	Holds Upper End of Handles		D-3733
361		Flexible Shaft and Coupling	5 ¹ / ₂ inches Long, Including Couplings Special	Operates C-W Osc. Control	SSW	D-3736
362		Extension Shaft	Special Shaft 0.594 inches Long	Operates Crystal OUT-IN Switch		D-3739

APPENDIX

Reference No.	Signal Corps. Stock No.	Name of Part	Description	Function	Mfg. Symbol	Dwg. No.
363		Shaft and Coupling Assembly	Flexible Shaft with Insulated Coupling	Operates Antenna Trimmer		D-3741
364		Switch Shaft	Flat Shaft	Operates Band Switch	PRM	D-3861
366		Dial Mask Assembly	Plate with Cutouts	Masks Undesired Dial Scales	RMC	D-5028
367		Dial Assembly	Calibrated Circular Dial with Hub and Large Spur Gear	Gives Frequency setting	RMC	D-5027
368		Stop Arm Assembly	Lever with Roller and Pawl	Stops Condenser at End of Travel		D-3592
369		Index Plate	Phosphorus Bronze Strip Painted Red	Dial Scale Index		D-3607
370		Stop	Cast Bushing with Key	Stops Stop Arm		D-3608
371		Stud	Shouldered Stud Threaded No. 4-40 One End	Pivot Pin for Part 368		D-3609
372		Guide Assembly	Arm and Roller Assembly	Engages Index Wheel for Switch Locations		D-3613
373		Spring	Coiled Spring	Operation of Indexing Arm Item 372		D-3619
374		Gear and Pinion Assembly	Spur Gear and Pinion Assembly	Idler Reducing Gear Between Tuning Shaft and Dial		D-3623
375		Pinion	Pinion (Pinned to Tuning Shaft)	Dial Drive Pinion Meshing with Item 374	QCG	D-3642
376		Worm	Worm, Single Pitch	Drives Cross Shaft of Condenser Drive		D-3643
377		Gear Assembly	Split Worm Wheel	Part of Condenser Drive Train		D-3644

TABLE OF REPLACEABLE PARTS

Reference No.	Signal Corps. Stock No.	Name of Part	Description	Function	Mfg. Symbol	Dwg. No.
378		Pinion and Bushing Assembly	Pinion on Cross Shaft	Drives Tuning Condenser Gear		D-3648
379		Spring	Torsion Spring	Holds Items 368	HPS	D-3656
380		"C" Washer	"C" Washer	Against Dial Used to Retain Items 372 and 374		D-3657
399	2Z6694B	Mounting	Mounting Base Assembly	Supports Receiver		D-4013
400		Mounting Plate Assembly	Part of Ref. 399	Supports Item 401	DMD	D-4014
401		Base and Stiffener Assembly	Part of Ref. 399	Supports Receiver and Plug Item 403 or 404	DMD	D-4019
402		Cap Screw	1/4-20 x 1 1/8 Long	Holds Items 401, 400 Together.		D-4027
403	2Z7203.2	Plug PL-P103	8 Pole Female Power Connector	Makes Connection to Exterior Equipment	AP	D-3811
404	2Z7203.1	Plug PL-Q103	8 Pole Female Power Connector	Makes Connection to Exterior Equipment	AP	D-3812
405		Jack Block	Part of Ref. 403 and 404	Holds Contactors	AP	D-4074
406		Jack Block	Part of Ref. 403 and 404	Holds Contactors	AP	D-4075
407		Jack Block	Part of Ref. 403 and 404	Holds Contactors	AP	D-4076
408		Jack Block	Part of Ref. 403 and 404	Holds Contactors	AP	D-4077
409		Jack Housing Assembly	Part of Ref. 403 and 404	Houses Jack Blocks	AP	D-4060
410	2Z7203.1/1	Fitting (Right Angle)	Part of Ref. 404	Cable Protection and Shielding	AP	D-4063
411	2Z7203.2/1	Fitting (Straight)	Part of Ref. 403	Cable Protection and Shielding	AP	D-4064
412		Contact Spring Assembly	Part of Ref. 403 and 404	Contact	AP	D-4078

APPENDIX

Reference No.	Signal Corps. Stock No.	Name of Part	Description	Function	Mfg. Symbol	Dwg. No.
413		Jack Housing Cover	Part of Ref. 403 and 404	Covers Jack Block Terminals	AP	D-3062
414		Cover	Part of Ref. 257	Top		D-3420
415		Cover	Part of Ref. 257	Bottom		D-3454
416		Shield	Part of Ref. 257	Side and Ends		D-3419
417		Cover	Part of Ref. 258	Top		D-3488
418		Cover	Part of Ref. 258	Bottom		D-3454
419		Shield	Part of Ref. 258	Side and Ends		D-3478
420		Cover	Part of Ref. 259	Top		D-3488
421		Cover	Part of Ref. 259	Bottom		D-3451
422		Shield	Part of Ref. 259	Side and Ends		D-3490
423		Cover	Part of Ref. 260	Top		D-3540
424		Cover	Part of Ref. 260	Bottom		D-3534
425		Cover	Part of Ref. 260	Side		D-3536
426		Shield	Part of Ref. 260	Side and Ends		D-3509
427		Shield Can	Part of Ref. 251	Top	FWS	D-3835
428		Shield Can	Part of Ref. 252	Top	FWS	D-3835
429		Shield Can	Part of Ref. 253	Top	FWS	D-3835
430		Shield Can	Part of Ref. 254	Top	FWS	D-3792
431		Shield Can	Part of Ref. 255	Top	FWS	D-3815
432		Shield Can	Part of Ref. 256	Top	FWS	D-3792
433		Tube Guide	Cylindrical Socket for Tube Base	Supports Tube VT-70 and Tube Shield	OVC	D-3839
434		Tube Guide	Cylindrical Socket for Tube Base	Supports Tube VT-48	OVC	D-3838
435		Shield Can —Less Top	Part of Ref. 251	1st I-F Transformer Assembly Shield	FWS	D-3785

TABLE OF REPLACEABLE PARTS

Reference No.	Signal Corps. Stock No.	Name of Part	Description	Function	Mfg. Symbol	Dwg. No.
436		Shield Can —Less Top	Part of Ref. 252	2nd I-F Transformer Assembly Shield	FWS	D-3785
437		Shield Can —Less Top	Part of Ref. 253	3rd I-F Transformer Assembly Shield	FWS	D-3785
438		Shield Can —Less Top	Part of Ref. 254	4th I-F Transformer Assembly Shield	FWS	D-3785
439		Shield Can —Less Top	Part of Ref. 255	Crystal Filter Assembly Shield	FWS	D-3786
440		Shield Can —Less Top	Part of Ref. 256	C-W Osc. Assembly	FWS	D-3785
500	2C4348M/R2	Resistor	Variable 200 ohms $\pm 10\%$ Special, 4 watts	Dial Lamp Control	PRM, CTS	D-3880
501-A	3Z5993-2	Resistor	Insulated 3 ohms $\pm 10\%$ 1.5 watts, special	Filament	IRC	D-3937
501-B			190 ohms $\pm 10\%$ 1.9 watts, special			
502	3Z1935	Fuse FU-35	5 Amp., 25 Volts Type 1094	Primary Power	LL	D-3886
503	3Z6006-3	Resistor	Insulated 60 ohms $\pm 10\%$ 3.7 watts Type MW-2	Dial Lamp Series	IRC	D-3888
504	2C4348M/F2	Fuse Clip Assembly	Laminated Phenolic Strip with Fuse Clips	Fuse Holder		D-3881
510	3H1628B	Dynamotor	27.9 V, 1.23 A, 220 V, 0.070 A, Type J-1054-A	Dynamotor Machine	E, WC	D-3890
511	3H1628M/A1	Armature	Part of Ref. 510	Dynamotor	E, WC	D-3569
512	3H1624B/3.1	Brush and Spring	Part of Ref. 510	Pos. L-V	E, WC	D-4350
513	3H1624B/3	Brush and Spring	Part of Ref. 510	Neg. L-V	E, WC	D-4351

Reference No.	Signal Corps. Stock No.	Name of Part	Description	Function	Mfg. Symbol	Dwg. No.
514 } 515 }		{ Field Windings	{ Field windings are available in pairs only. Part of Ref. 510	Dynamotor	WC	
VT-86		Vacuum Tube 6K7		1st R-F Amp.		
VT-86		Vacuum Tube 6K7		2nd R-F Amp.		
VT-91		Vacuum Tube 6J7		1st Det.		
VT-65		Vacuum Tube 6C5		Oscillator		
VT-86		Vacuum Tube 6K7		1st I-F Amp.		
VT-70		Vacuum Tube 6F7		C-W Osc. and 2nd I-F		
VT-93		Vacuum Tube 6B8		3rd I-F & 2nd Det.		
VT-48		Vacuum Tube 41		Audio Output Amp.		

37. LIST OF MANUFACTURERS

Manufacturer	Symbol
Acme Electric & Mfg. Co., Cuba, New York	AEM
Aerovox Corp., New Bedford, Massachusetts	A
Alden Products Co., Brockton, Massachusetts	AP
Allen-Bradley Co., Milwaukee, Wisconsin	AB
Aluminum Goods Mfg. Co., Manitowoc, Wisconsin	AG
American Radio Hardware, 476 Broadway, New York City	ARH
Arrow-Hart & Hegeman Co., Hartford, Connecticut	AHH
Automatic Winding Co., 900 Passaic Avenue, East Newark, New Jersey	AW
A. D. Cardwell Mfg. Co., 81 Prospect Street, Brooklyn, New York	ADC
Central Radio Laboratory, 900 E. Keefe Avenue, Milwaukee, Wisconsin	CRL
Chicago Transformer, 2626 W. Washington Blvd., Chicago, Illinois	CT
Chicago Telephone Supply Co., Elkhart, Indiana	CTS
Cinch Manufacturing Corp., 2335 W. VanBuren Street, Chicago, Illinois	CM
H. Cole & F. C. Hersee Co., 54 Old Colony Avenue, Boston Massachusetts	CH
Cornell-Dubilier Corp., South Plainfield, New Jersey	CD
Crowe Name Plate & Mfg. Co., 3701 Ravenswood Avenue, Chicago, Illinois	CN
Dahlstrom Metallic Door Co., Jamestown, New York	DMD
Doehler Diecasting Co., Batavia, New York	DDC
Eicor, Inc., 1060 W. Adams Street, Chicago, Illinois	E
Electro-Chemical Engraving Co., 1100 Brook Avenue, New York City	ECE
Electro-Motive Mfg. Co., S. Park & John Streets, Willimatic, Connecticut	EMC
Erie Resistor Corp., Erie, Pennsylvania	ER
General Electric Co., Bridgeport, Connecticut	GE
Edwin I. Guthman & Co., Inc., 15 S. Throop Street, Chicago, Illinois	EG
Hammarlund Manufacturing Co., 424 W. 33rd Street, New York City	HM
Hunter Pressed Steel, Lansdale, Pennsylvania	HPS
International Resistance Co., 401 N. Broad Street, Philadelphia, Pennsylvania	IRC
Littlefuse Laboratories, 4240 Lincoln Avenue, Chicago, Illinois	LL
P. R. Mallory & Co., 3029 E. Washington Street, Indianapolis, Indiana	PRM
Micamold Radio Corp., 1087-1095 Flushing Avenue, Brooklyn, New York	MR
National Lock Co., Rockford, Illinois	NL
Oak Manufacturing Co., 1260 Clybourn Avenue, Chicago, Illinois	OM
Oneida Vault & Casket Co., Oneida, New York	OVC
Quaker City Gear Co., Front & Berks Streets, Philadelphia, Pennsylvania	QCG
Radio Condenser Co., Camden, New Jersey	RC
Rochester Manufacturing Co., Rockwood Place, Rochester, New York	RMC
Sargent & Greenleaf Inc., Rochester, New York	SG
F. W. Sickles Co., Springfield, Massachusetts	FWS
Solar Manufacturing Co., Bayonne, New Jersey	SMC
Sprague Specialties Co., North Adams, Massachusetts	SS
Standard Transformer Corp., 1500 N. Halsted Street, Chicago, Illinois	ST
Webster-Chicago Corp., 3825 W. Armitage Avenue, Chicago, Illinois	WC
Westinghouse Electric & Manufacturing Co., 2519 Wilkens Avenue, Baltimore, Maryland	WE
S. S. White Dental Co., 10 E. 40th Street, New York City	SSW

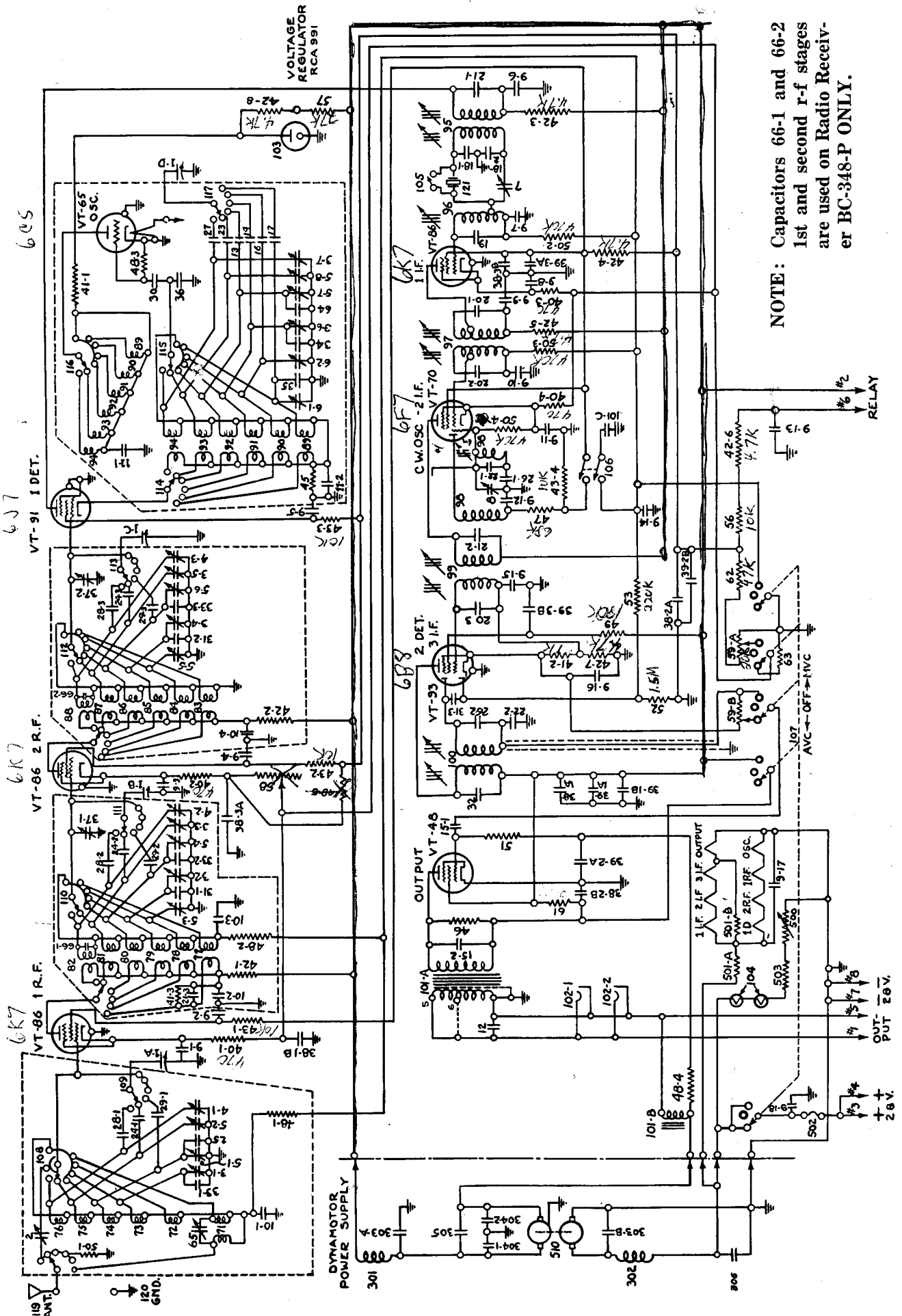
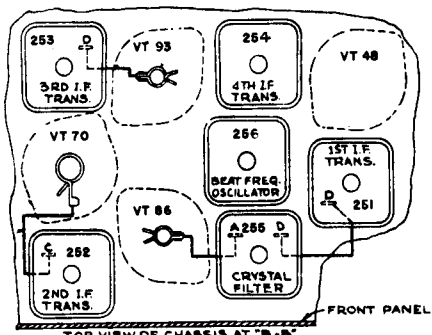
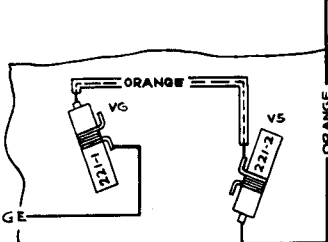
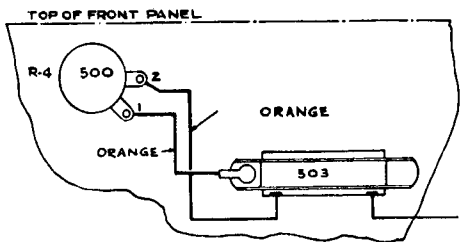
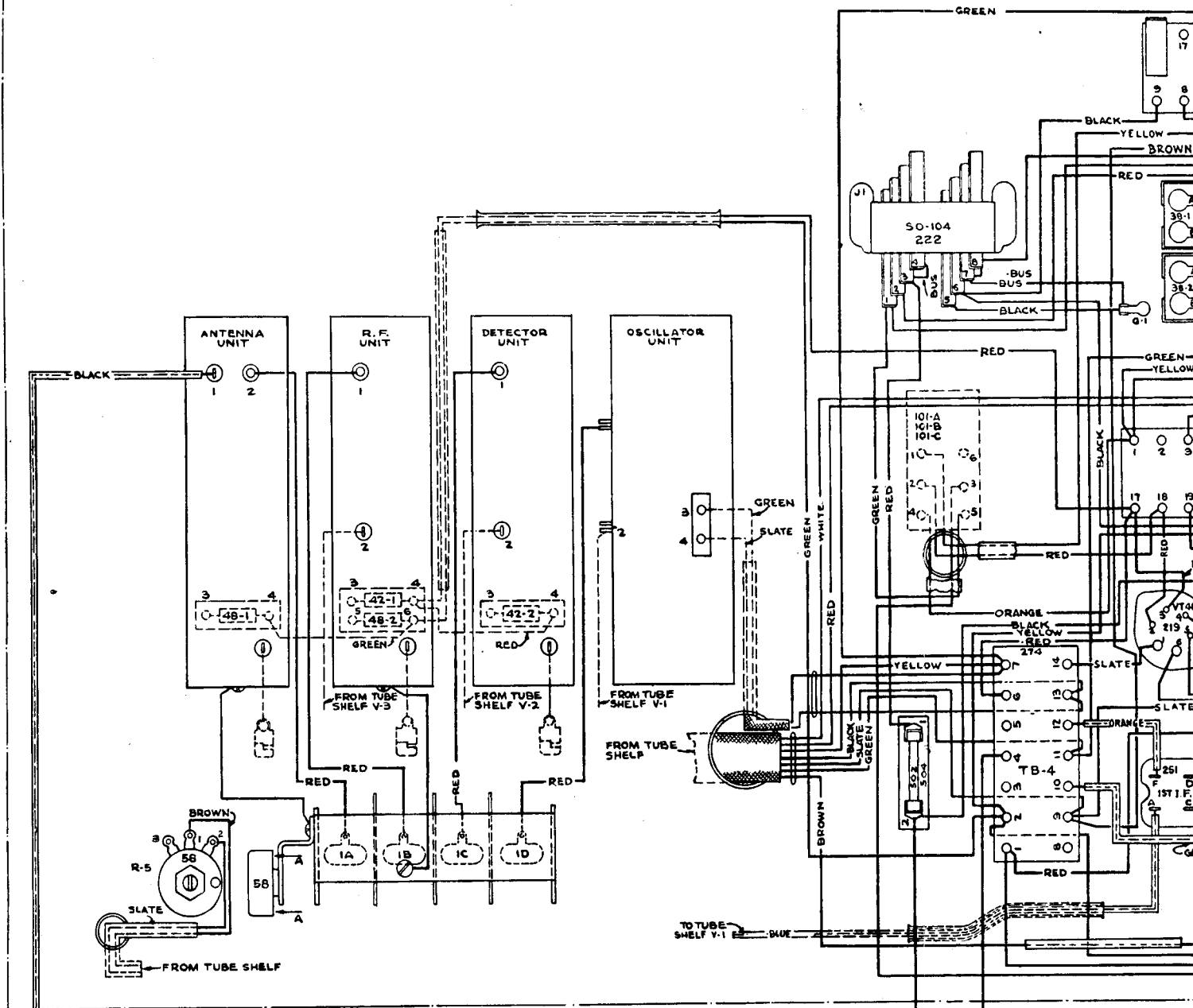

FIGURE 29—SCHEMATIC DIAGRAM



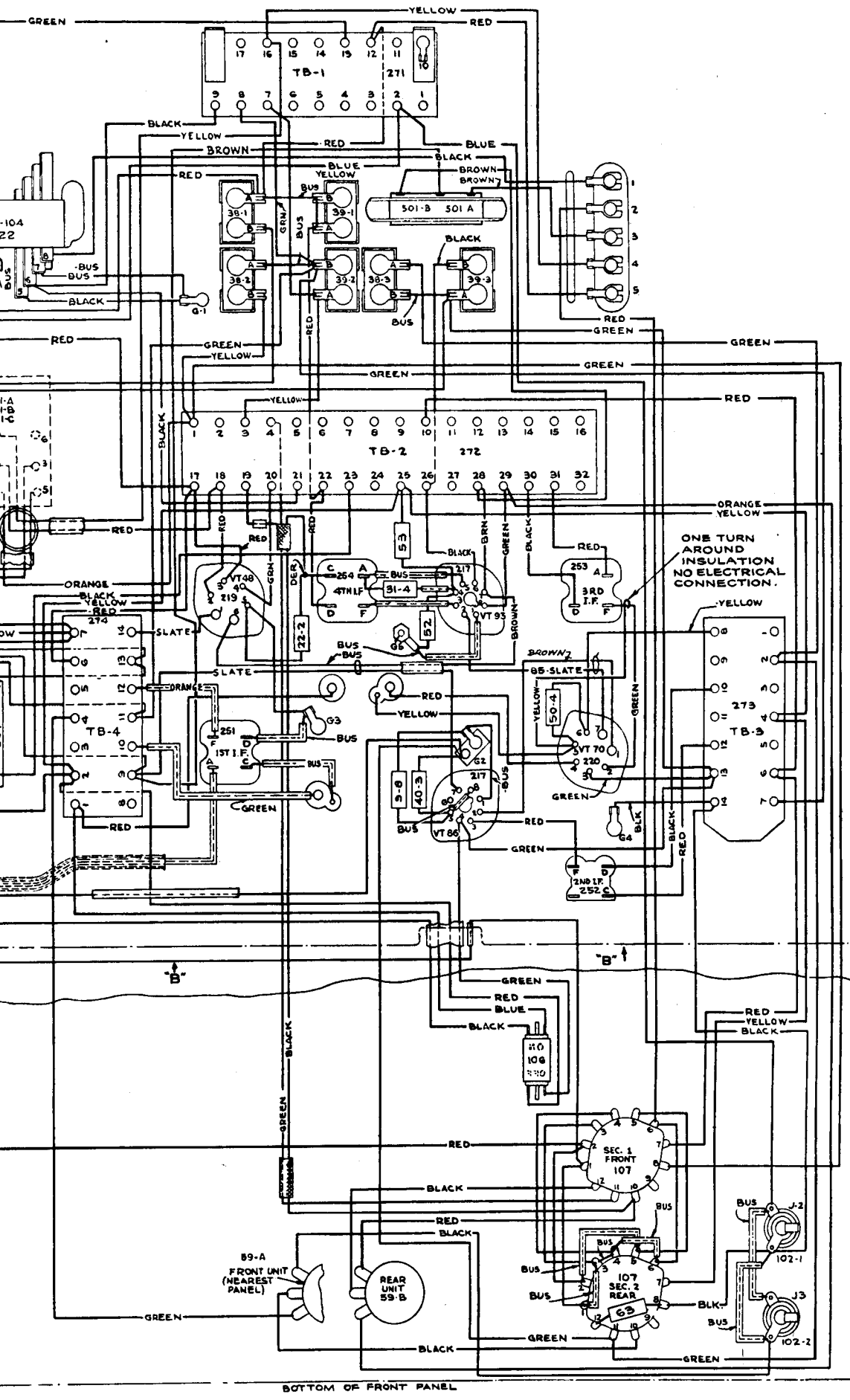

FIGURE 30—WIRING DIAGRAM

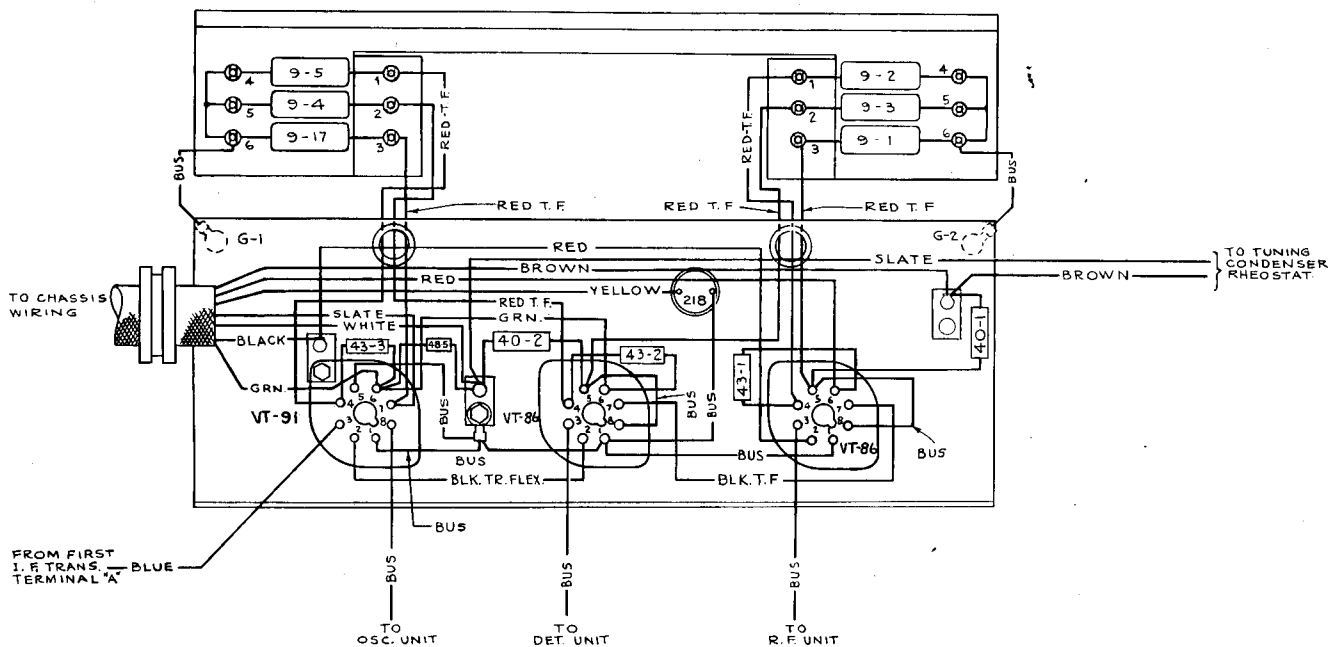

FIGURE 31—TUBE SHELF WIRING DIAGRAM (FOR EXTERNAL CONNECTIONS SEE FIG. 30)

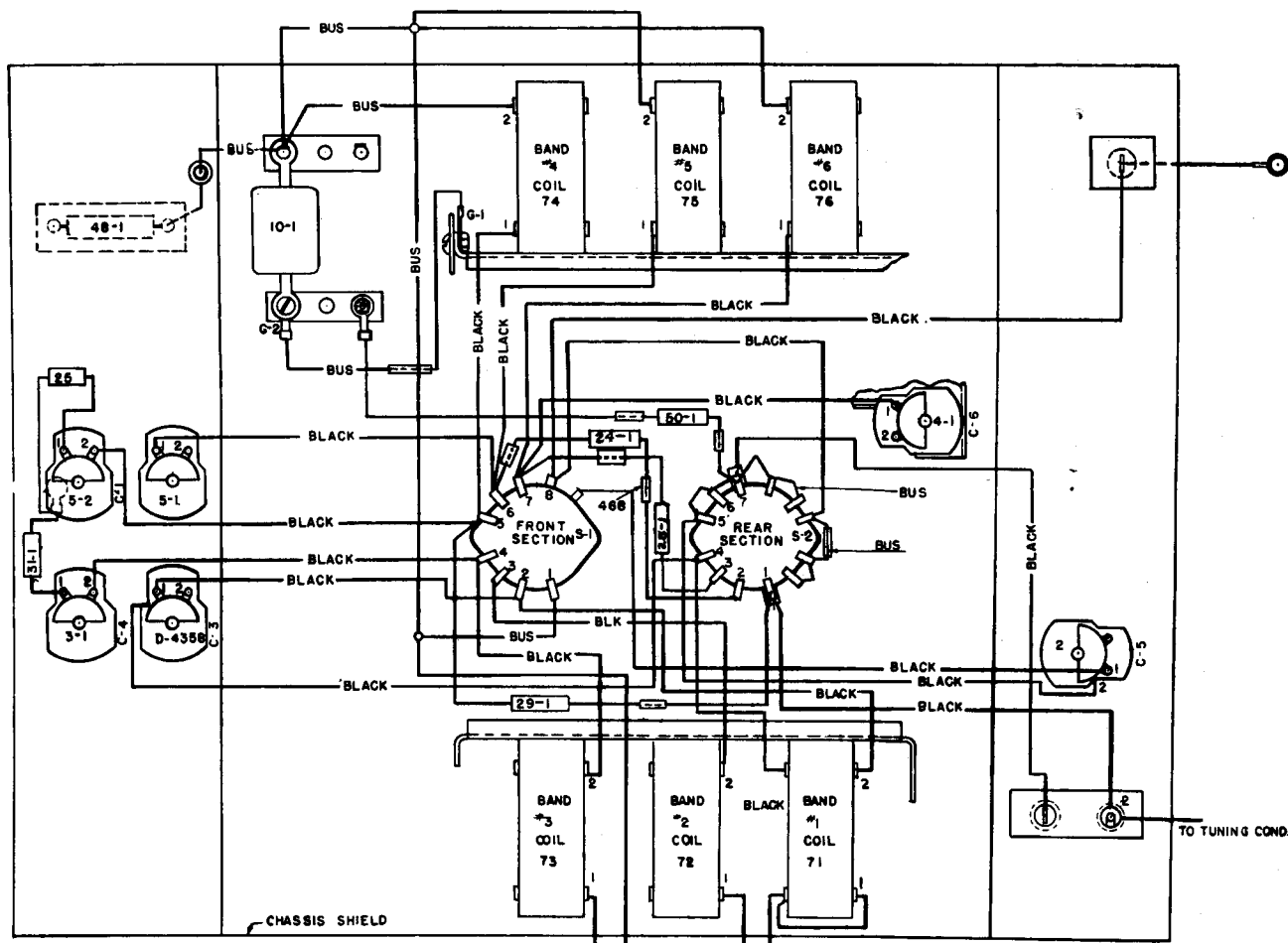

FIGURE 32—ANTENNA UNIT WIRING DIAGRAM (SEE FIG. 30)

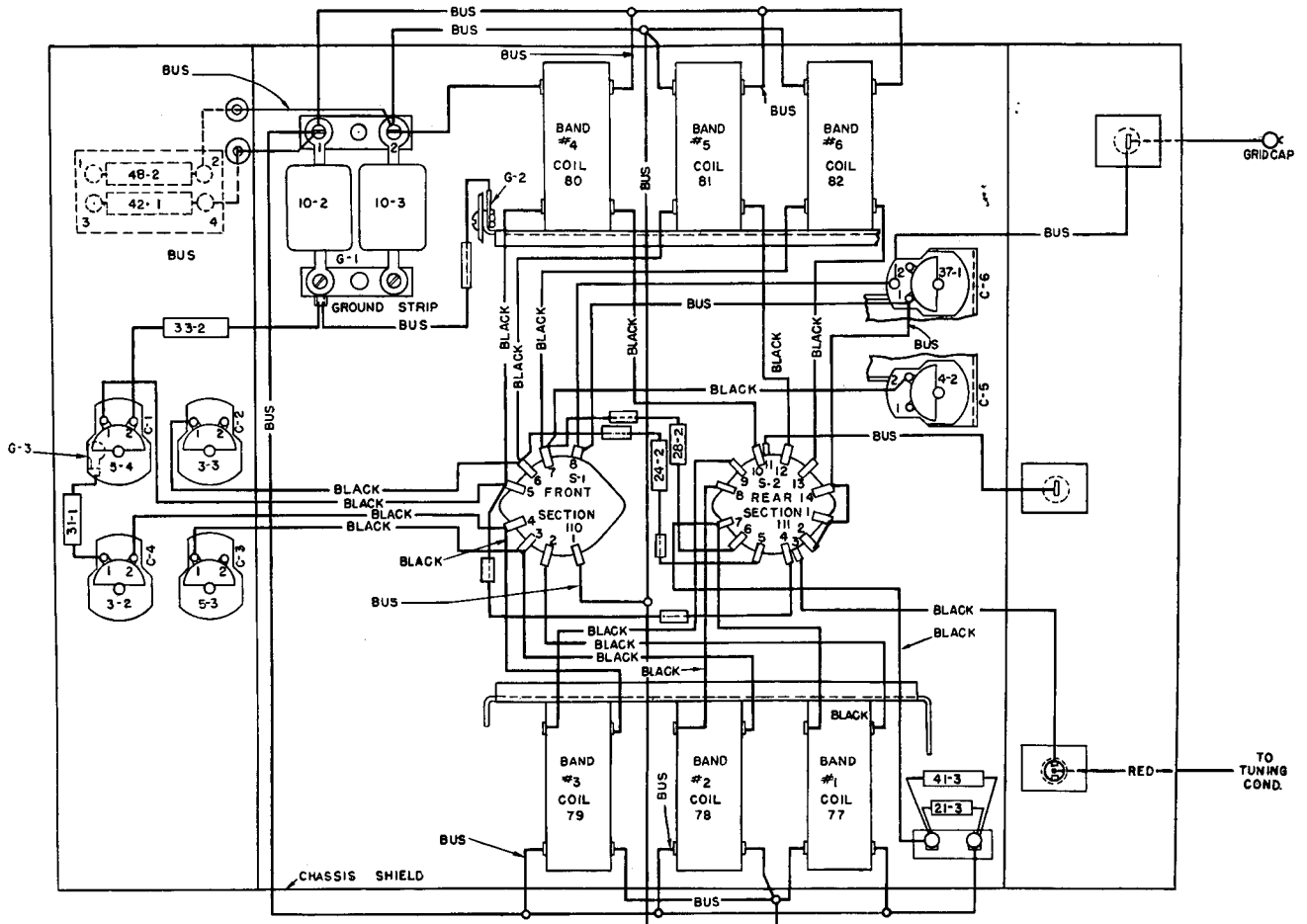

FIGURE 33—R-F UNIT WIRING DIAGRAM (SEE FIG. 30)

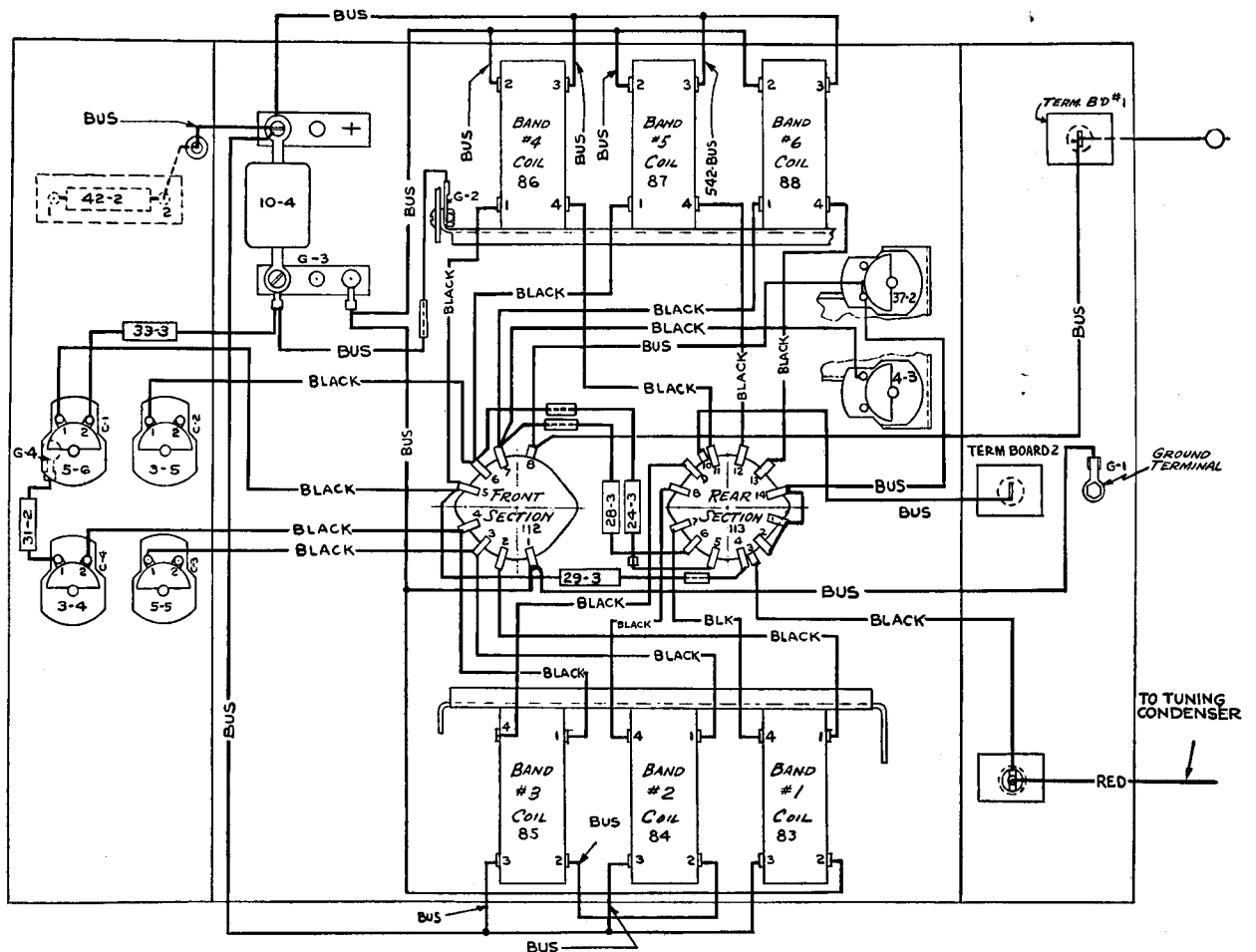

FIGURE 34—DETECTOR UNIT WIRING DIAGRAM (SEE FIG. 30)

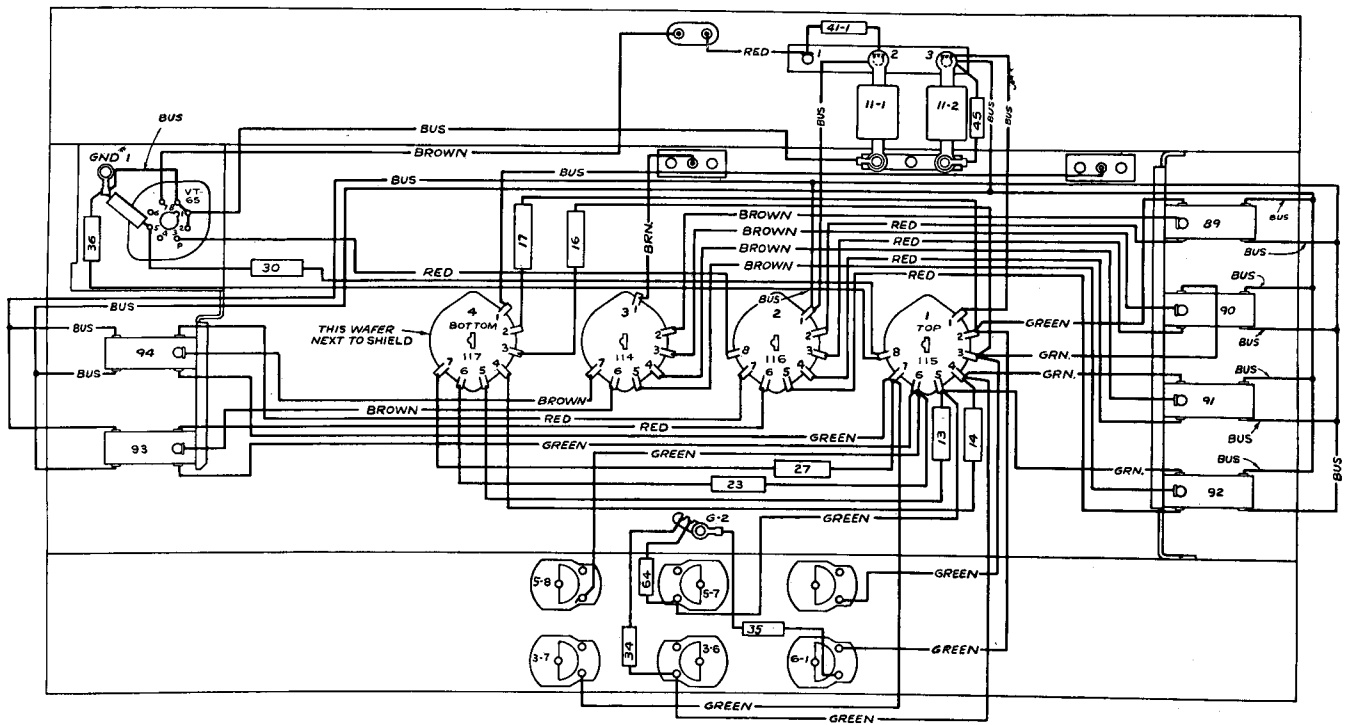

FIGURE 35—OSCILLATOR UNIT WIRING DIAGRAM

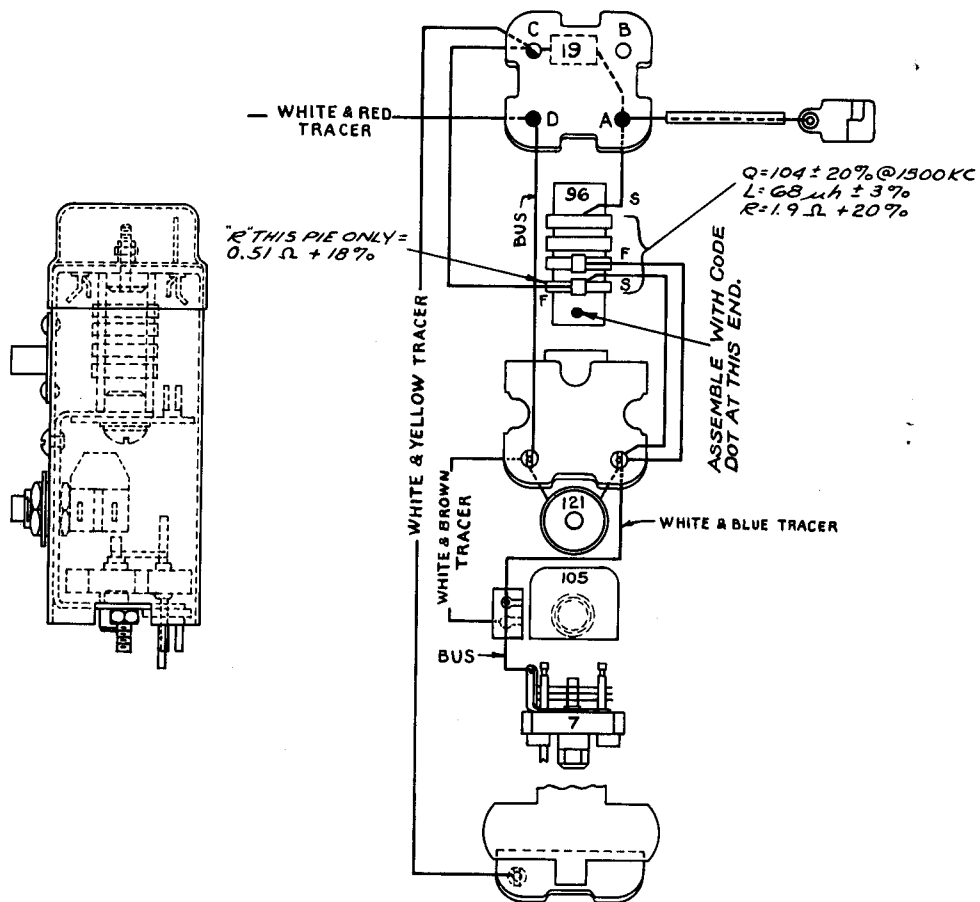

FIGURE 36—CRYSTAL FILTER WIRING DIAGRAM

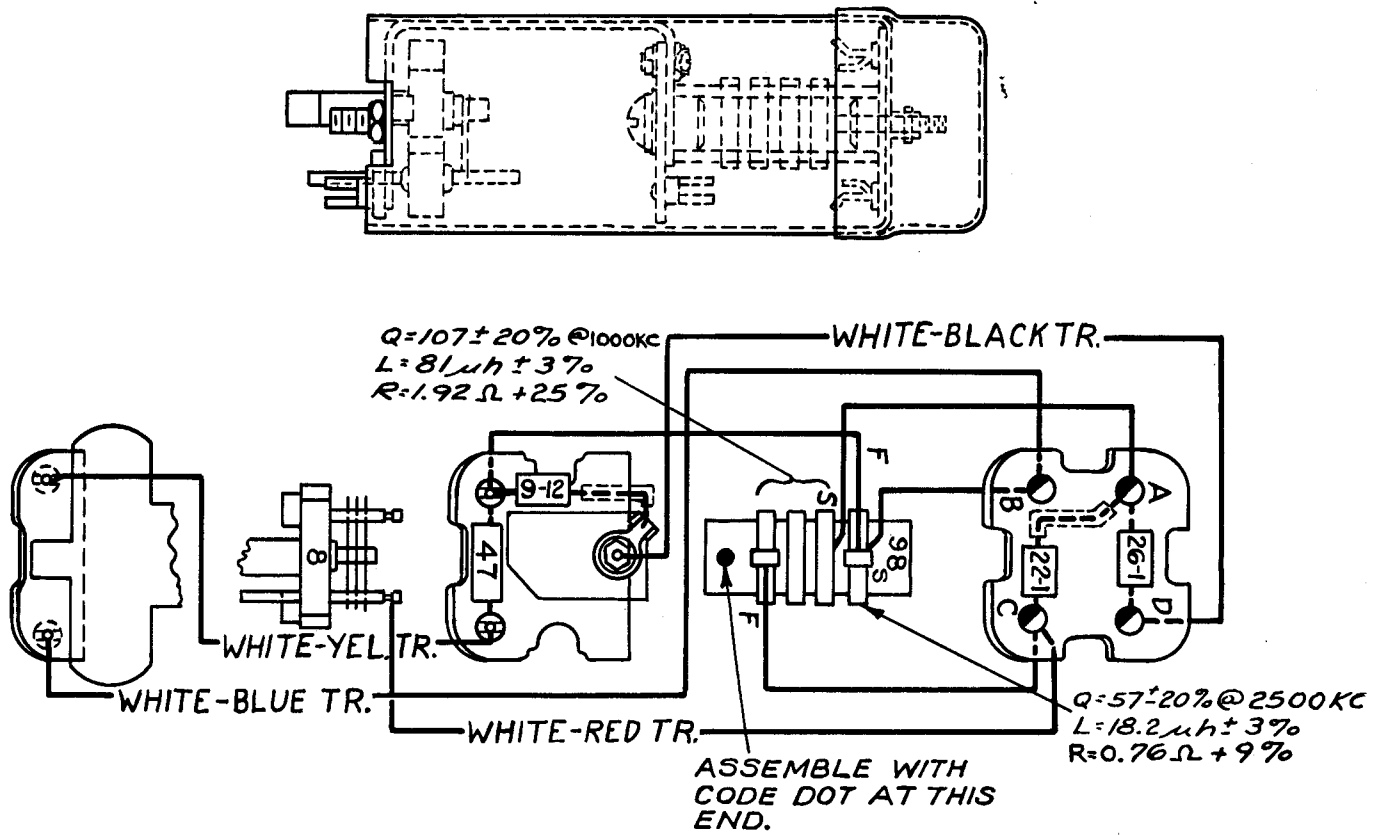

FIGURE 37—WIRING DIAGRAM C-W OSCILLATOR ASSEMBLY

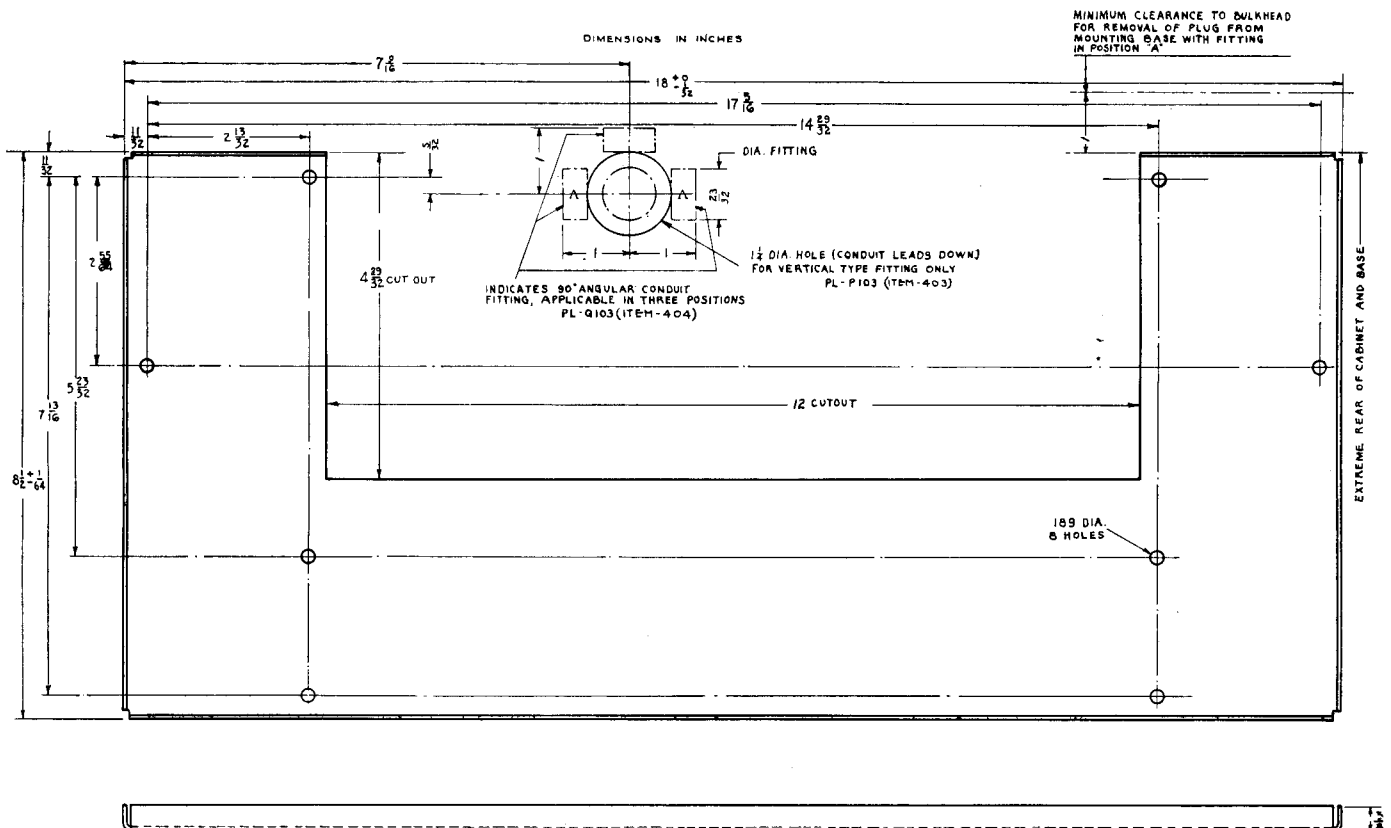

FIGURE 38—DRILLING PLAN FOR MOUNTING BASE

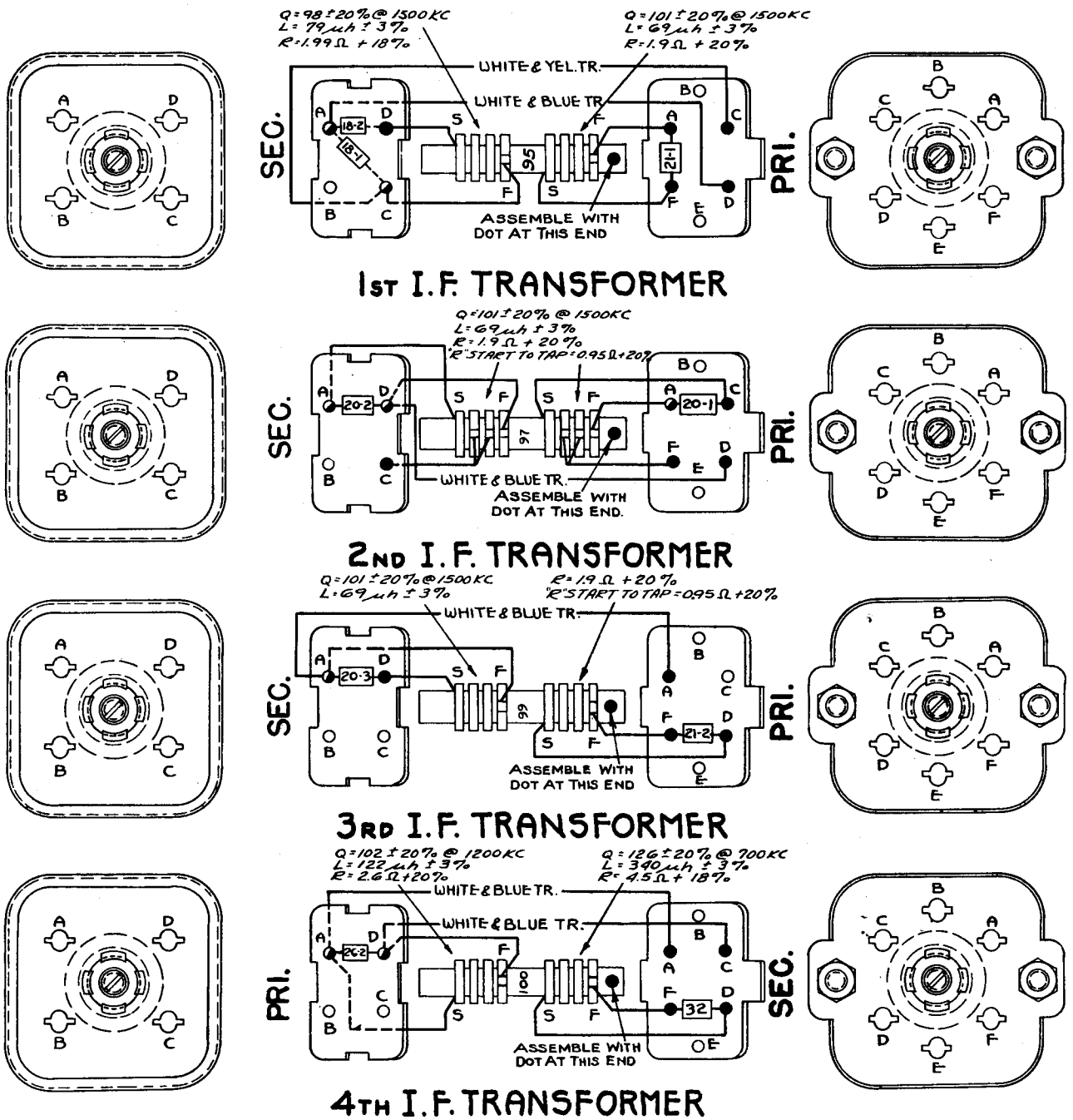

FIGURE 39—WIRING DIAGRAM, INTERMEDIATE FREQUENCY TRANSFORMERS

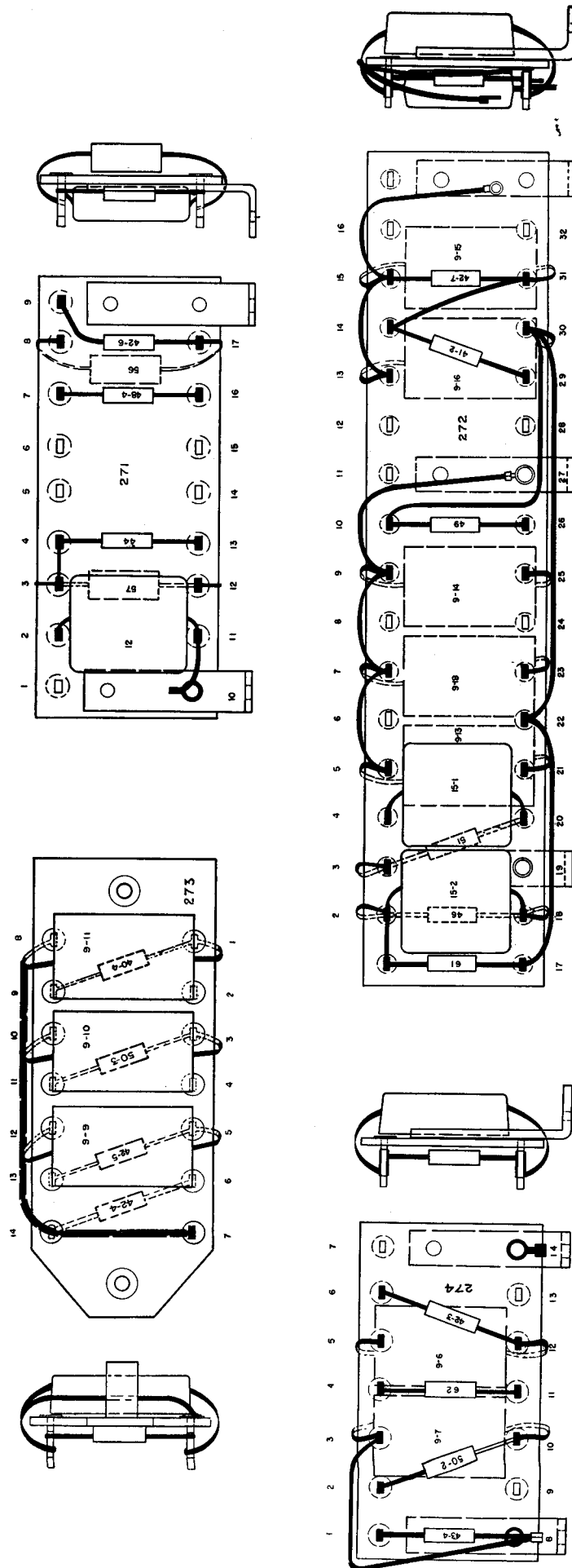

FIGURE 40—WIRING DIAGRAM, RESISTOR BOARDS

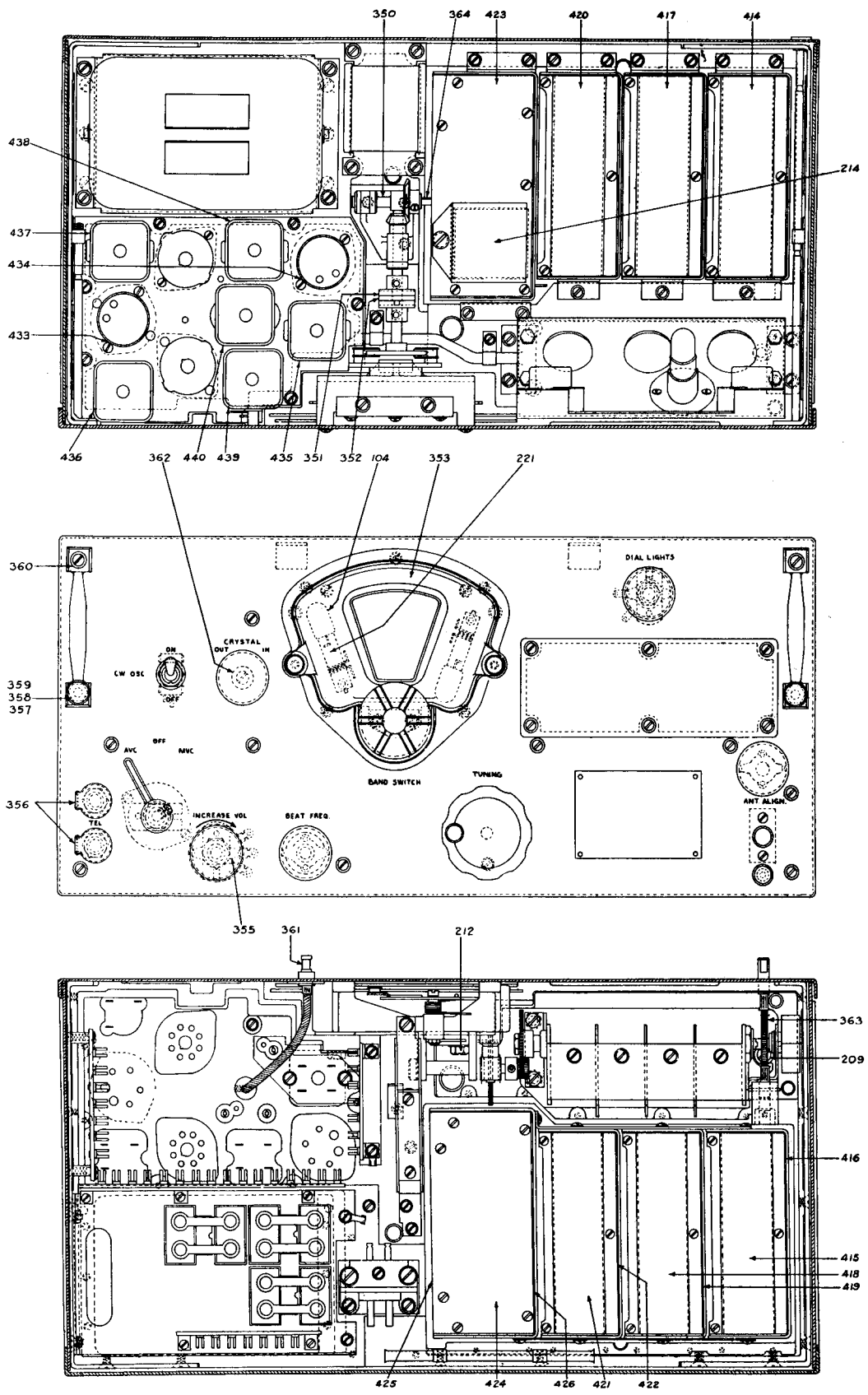

FIGURE 41—DETAIL VIEWS, TOP, PANEL AND BOTTOM

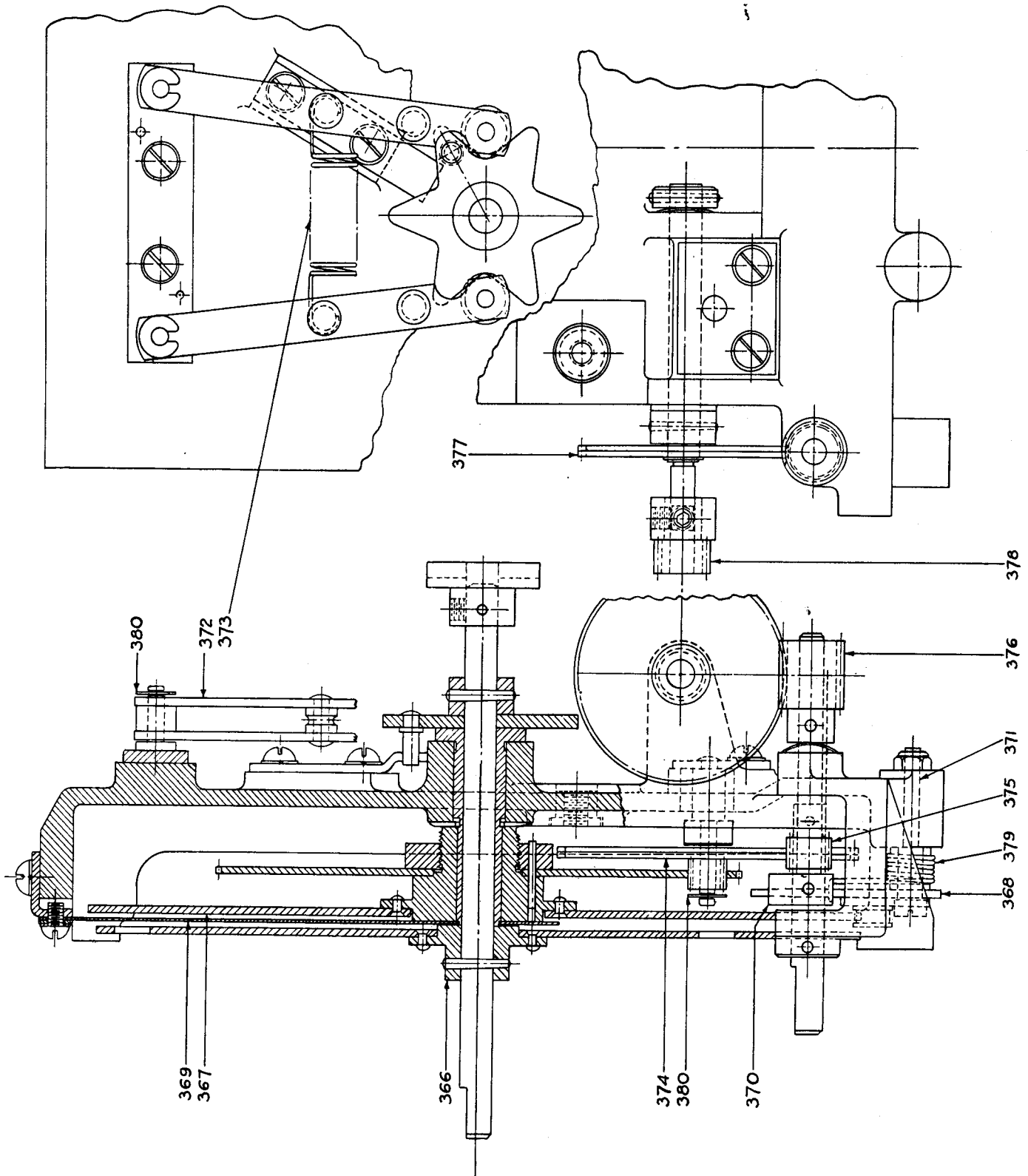

FIGURE 42—DETAILS OF PRECISION DIAL MECHANISM AND MASK ASSEMBLY

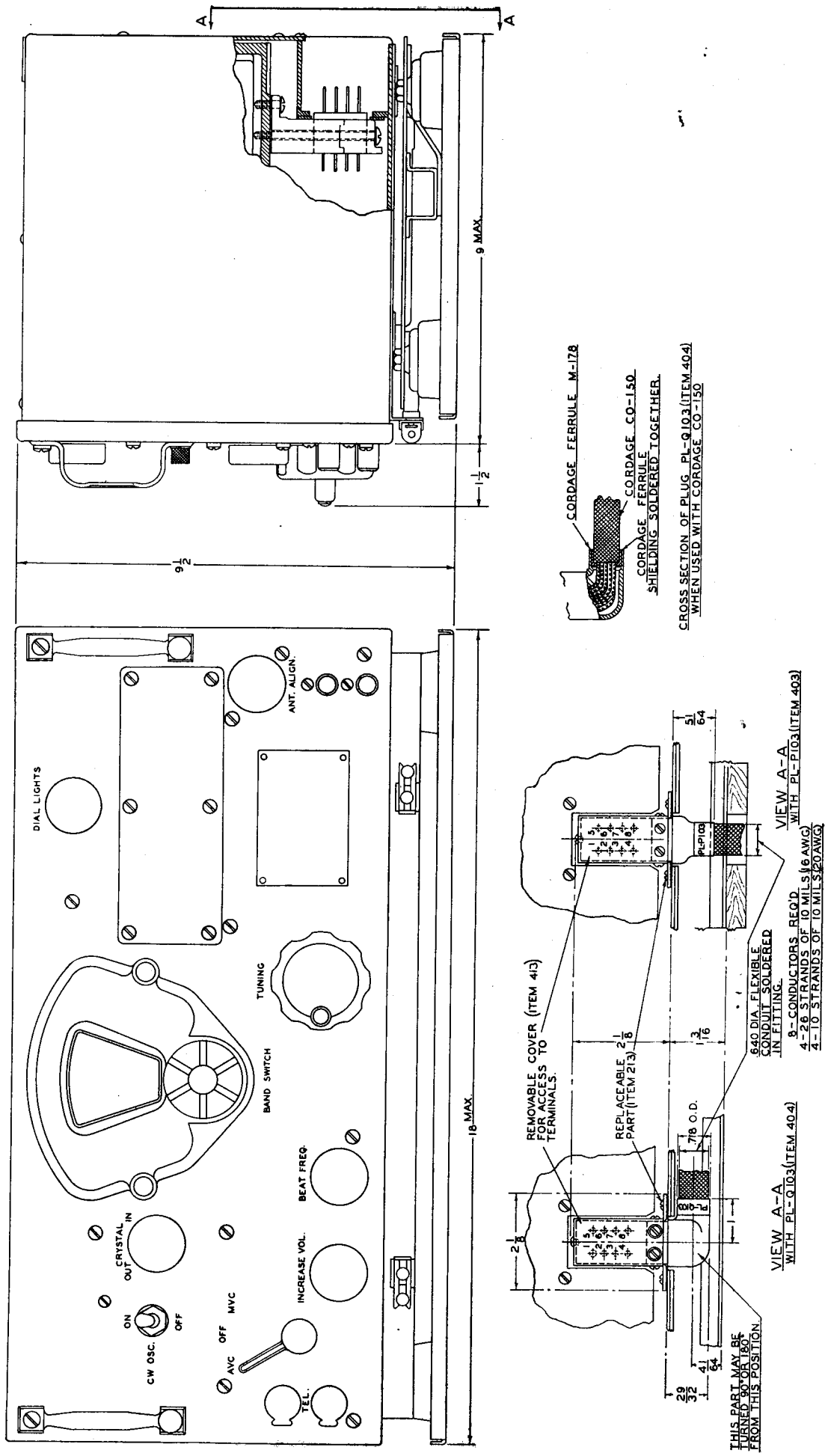

FIGURE 43—DIMENSIONAL VIEWS AND CABLE PLUG DETAILS